

P-Series

The P-series humidifiers can set the humidity, temperature and flow rate of a gas. The equipment is accurate, easy-to-use and reliable - Developed for laboratory experiments and for continuous operation in industrial production.

The P-Series is suitable for flow rates in the range 0 to 250 litres per minute and pressures from vacuum up to 20 bar(a).

The P-Series is available in versions from the basic version to full-feature units for full control and wide operating range of humidity, temperature, flow and pressure.



Advantages

- No condensation at low flow rate, down to 0 l/min
- No droplets at full flow
- Fully automatic
- Maintenance free
- Compact
- Suitable for air, oxygen, hydrogen and other gases.

Humidity control

- Industrial production and laboratory
- Climate chambers
- Environmental simulation
- Fuel Cell testing
- Semiconductor industry
- Tube furnaces
- Pharmaceutical industry
- Humidity control of vacuum dryers

Technology

- Membrane humidifier for accurate humidity control without droplets
- Microprocessor controlled digital display.
- Stainless steel and PTFE components
- CE-compliance

Principle

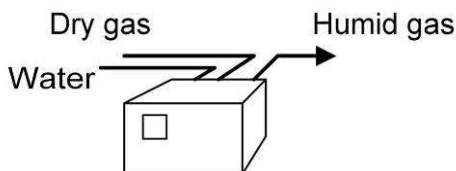

Capacity

Model	P-2	P-10	P-50	P-100	P-250
Flow (l/min)	0...2	0...10	0...50	0...100	0...250
Humidity	0...100 % RH -40...90 (125 °C) Tdew				
Temperature	20...300 °C				
Pressure	0...20 bar(a)				

Display

The front panel display will give all information about the produced gas flow. The P-Series can control the humidity and optionally: flow rate, temperature, pressure and gas composition.

SP Flow (%)	100
SP RH (%)	60,0
RH (%)	59,9
SP Temp. (°C)	32,0
Temp (°C)	32,0

Transient and stable

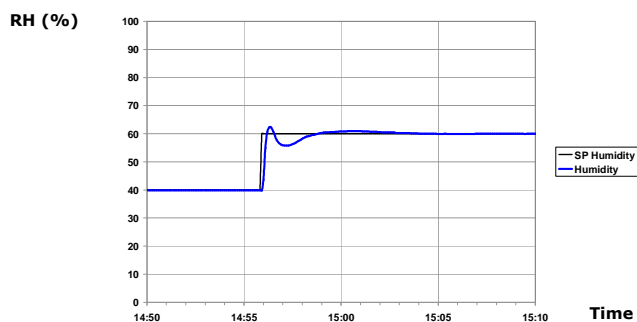

The graph shows the setpoint and the process value of humidity for a P-10 unit at max flow (10 NI/min). Even quicker transients are available upon request.

Technical data

	P-2	P-10	P-50	P-100	P-250
Flow					
Capacity	0...2 l/min	0...10 l/min	0...50 l/min	0...100 l/min	0...250 l/min
Flow accuracy (flow control option)	± 0.5 % reading ± 0.1 % of full scale				
Humidity					
Capacity ¹	0...100 % RH, -40...90 (125 °C) Tdew				
Sensor accuracy	± 1.5 %RH				
Sensor accuracy (configuration for atm pressure and max 75 °C)	At 0 ... +40 °C: ±1.5 % RH (0 ... 90 %RH) ±2.5 % RH (90 ... 100 %RH) At +40 ... +80 °C: ±3.0 % RH (0 ... 90 %RH) ±4.0 % RH (90 ... 100 %RH)				
Temperature					
Capacity	20...300 °C				
Accuracy at 0 ... +40 °C gas temperature	±0.2 °C				
Pressure					
Pressure range	0.8...1.2 bara (atm), 1...6 bar(a) or free def. between 0 (vacuum)...20 bar(a)				
Pressure drop	2500 mbar with flow control, 0-800 mbar without flow control				
Pressure drop (low limited versions)	50 mbar	50 mbar	300 mbar	150 mbar	300 mbar
Liquid supply					
Water quality	Deionised or distilled (max 10µS / cm)				
Suction capacity of inlet water	1 m				
Max pressure of inlet water (optional)	8 bar				
General					
Power	1000 W	1200 W	2000 W	2000 W	2400 W
Ambient temperature in use	+5... +45 °C				
Ambient temperature storage	-40... +60 °C				
Start-up time to Tdew 50 °C	5 min				
Wetted materials	Perfluorinated sulphonic acid membrane, PTFE, Stainless steel				
Certification	CE certified				
Mechanical					
Standard bench top enclosure (WxHxD)	471x280.5x391 mm				
Weight	15 kg	15 kg	15 kg	23 kg	25 kg
Interface					
Voltage	208-230 V / 50-60 Hz AC				
Remote control digital (optional)	RS 232 / RS 485 Modbus RTU or Modbus TCP Open source Java-based software included with data logging, real time graphs and an advanced recipe function.				
Remote control analogue (optional)	4...20 mA				
Liquid inlet	6 mm or 1/4" compression fitting Swagelok®				
Gas inlet/outlet (Swagelok® fitting)	1/8", 6 mm or 1/4"	6 mm or 1/4"	12 mm or 1/2"		

¹Min level of humidity=Inlet gas humidity

Capacity

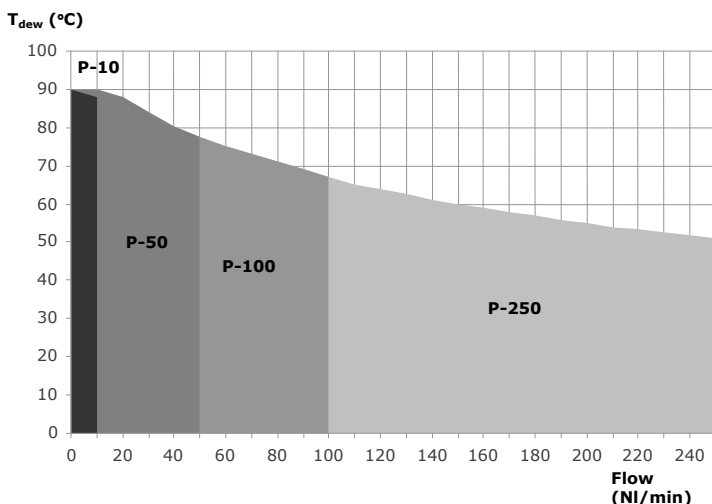

Industrial version

The P-Series humidifier is available in a version for industrial environments. The wall mount stainless steel enclosure is IP65 and also available with ATEX rating.



Accurate • Easy to use • Reliable

Function

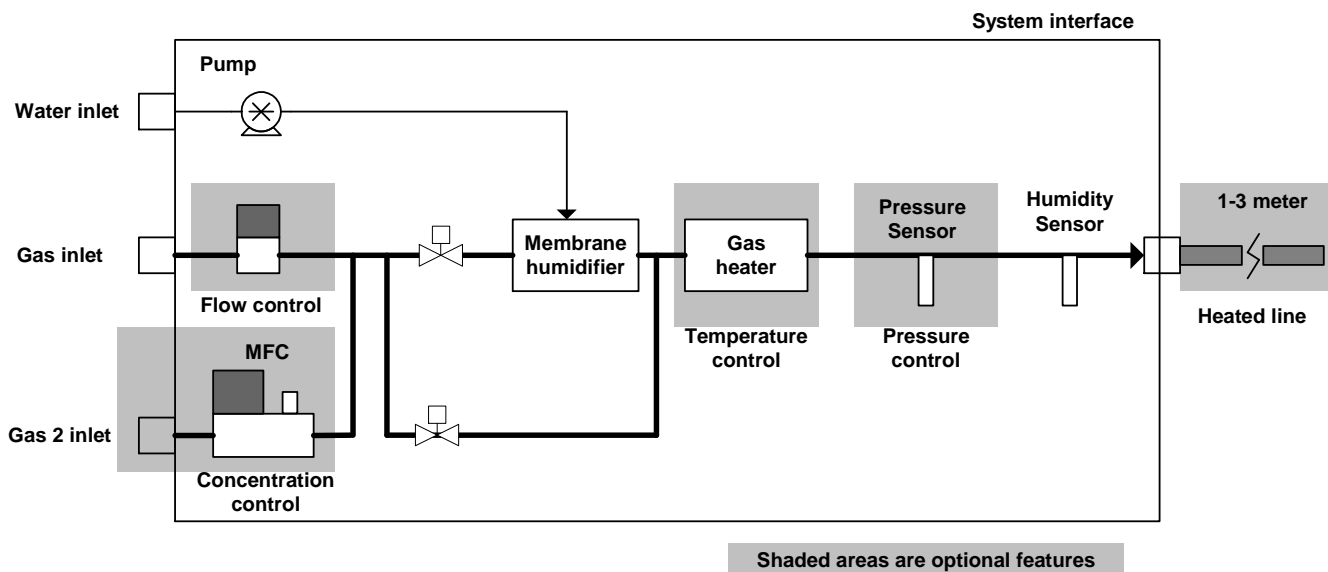

Flow

In standard configuration the unit can control the flow rate from 0-100%. Optionally the unit can be equipped with flow monitoring device that allows for precise control and readout of the flow rate in terms of nlpm or nccm.

Pressure

The unit can be configured to monitor the gas pressure or even to set the pressure. Pressure control is effectuated by controlling the flow rate in order to keep the pressure at the set value.

Temperature

The unit is available for output air/gas at room temperature or at increased temperature. An integrated internal heater will allow the user to set the temperature of the humidified gas. In this way the humidity and temperature can be set independently.

Humidity

In standard configuration the unit will control the humidity utilising two principles:

1. At low humidity the unit works by splitting the inlet flow in two paths. One stream is humidified as it passes through the membrane humidifier. The other stream is bypassed. Proportional valves control the mix-ratio of humid and dry flows to set the humidity at the set level.
2. At high humidity operation the entire flow is passed through the membrane humidifier and the temperature of the humidifier will control the output humidity. Change between the two modes is seamless and humidity can be varied quick and accurate in the entire humidity interval at the set temperature.

Concentration

Optionally the unit can be equipped with parallel flow control for several gases. In this way accurate concentration control can be achieved.

The core – the membrane humidifier

The core of the P-Series humidifier is the membrane humidifier. In this unit the dry flow is in humidified by transfer of water molecules through membrane tubes. The concept allows for large surface area and high capacity humidification in compact dimensions. The humidity transfer is linked to the water vapour pressure. It is increased at higher temperatures and controlled by setting the temperature of the water surrounding the membrane tubes. The Cellkraft membrane concept gives extremely stable performance in the full flow range. No droplets at neither low nor high flow rate. The unit can be operated in the range from zero to full flow.

Product configuration code

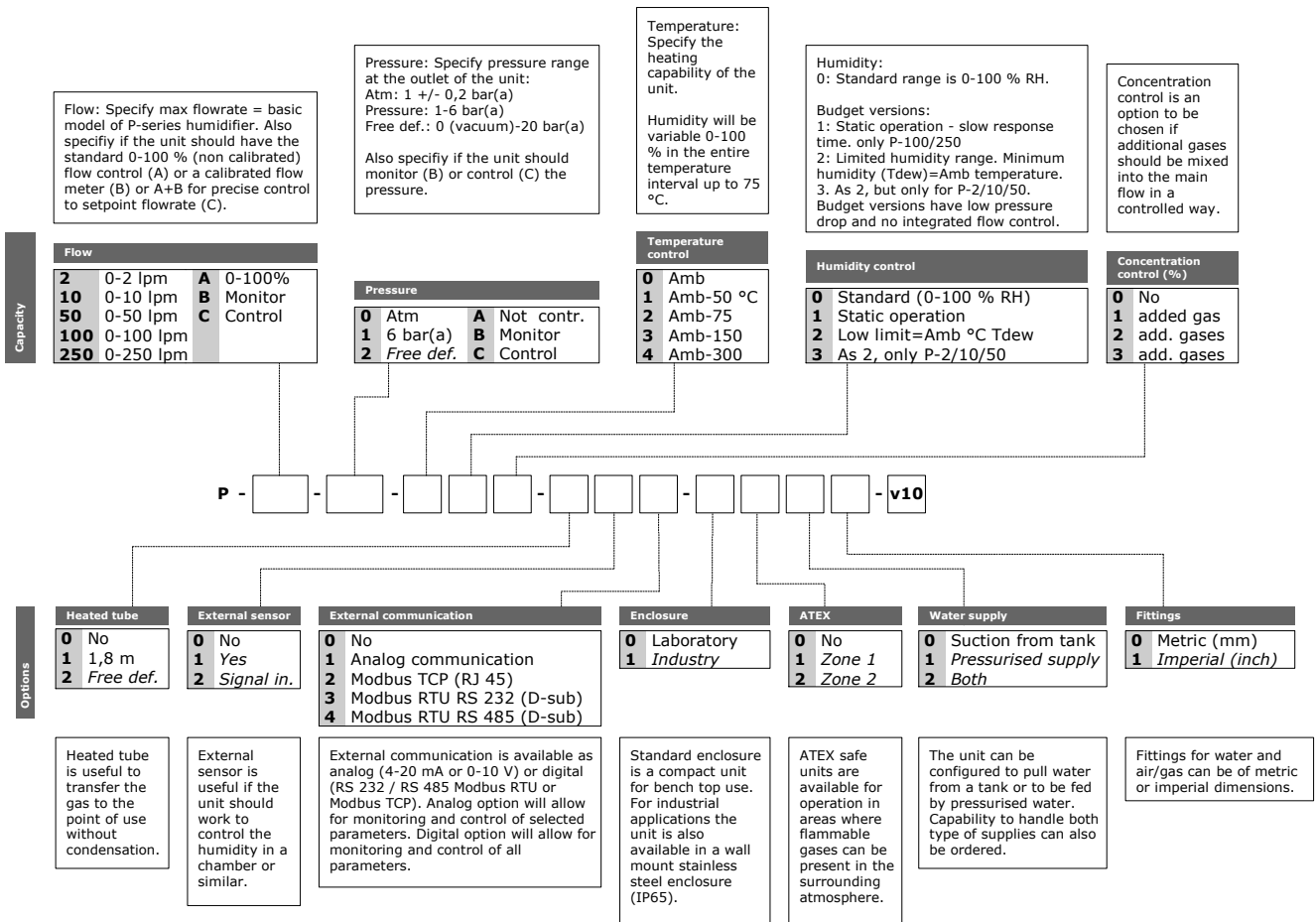

Example configuration code: **P-50A-0A-100-102-0000-v10**

This code describes a P-50 unit, capable of humidifying 50 liters/min with the standard 0-100 % flow control (including no calibrated flow meter). Operating pressure is 0.8-1.2 bar(a) (+/- 0.2 bar from atmospheric/normal ambient pressure.) Temperature of the outlet gas can be set from 25 to 50 °C. Humidity can be varied from 0 to 100 % RH.

The unit has a 1,8 meter long heated tube on the outlet to avoid condensation. It can communicate by digital communication, Modbus TCP by an RJ 45 connector) The unit has a standard enclosure to be placed on a lab bench or similar. It is not ATEX rated. The unit is prepared to pull water from a tank. It has metric (mm) fittings. The last position shows that the configuration key is version 10.