



**MEE INDUSTRIES, INC**

**HIGH PRESSURE HUMIDIFICATION  
ENGINEERING APPLICATION MANUAL**

Release 1.4  
September 1, 2007

# TABLE OF CONTENTS

1.0 The MeeFog Humidification Process .....	1
1.1 MeeFog Nozzles .....	1
1.2 MeeFog Humidification Systems .....	1
1.3 MeeFog Droplet Filters .....	3
2.0 HVAC Applications .....	4
2.1 HVAC Nozzle Placement .....	4
2.2 Nozzle Header Placement .....	5
2.3 Evaporation Efficiency .....	8
2.4 Determining the MeeFog Nozzles Required .....	8
2.5 Controlling Fog System Output—HVAC .....	8
2.6 Determining Control Increment .....	9
2.7 Determining Required Stages .....	9
2.8 Automatic Control of Staging Valves HVAC .....	10
3.0 In-Space Applications .....	12
3.1 In-Space Nozzles .....	12
3.2 In-Space Nozzle Header Installations .....	12
3.3 Automatic Control of Zone Valves .....	13
4.0 System Configuration .....	13
4.1 Humidification System Packaging .....	13
4.2 Maximum Number of Nozzles Per Valve .....	14
4.3 Layout and Installation .....	14
4.4 Control Panel Sizes .....	14
4.5 Humidifier Dimensions .....	14
5.0 Pumping Systems .....	14
5.1 Pump Cooling .....	14
5.2 Piping Requirements .....	15
5.3 Water Requirements .....	15
5.4 Water Treatment Systems .....	15
6.0 Installation Guidelines .....	17
6.1 Design Limitations .....	17
6.2 Material Storage and Handling .....	17
6.3 Installation Methods .....	17
6.4 In-Space Systems .....	17
6.5 HVAC Systems .....	18
6.6 Droplet Filters .....	19
7.0 Start-Up .....	20
7.1 Start-Up Procedure .....	20
8.0 Operation .....	21
8.1 Start-Up General Cautions .....	21
8.2 Fog System Drain Down .....	21
9.0 System Maintenance .....	22
9.1 Filter Maintenance .....	22
9.2 Pump Maintenance .....	22
9.3 To Change Pump Oil .....	22
9.4 Fog Nozzle Maintenance .....	22
9.5 Nozzle Cleaning Procedure .....	22
9.6 Nozzle Pin Damage .....	23
9.7 Removal Of MEE Nozzle Filters .....	24
9.8 Installation Of Mee Nozzle Filters .....	25
9.9 Improper Fog Nozzle Handling .....	26
10.0 Trouble Shooting Guide .....	27
Appendices .....	30

# M E E I N D U S T R I E S I N C

## Recommended Usage and Application Disclaimer

This high pressure humidification manual contains information believed to be accurate at the time of publishing. Mee Industries is not responsible for errors or improper use of the information contained within this publication, and the information is subject to change without notification..

The manual should be used to learn the proper design, installation and operation of Mee Fog systems. Drawings, pictures and diagrams contained herein should be considered typical and should not be used in the actual design process. Equipment arrangements and sizes change from time to time and the latest information should be obtained from your local rep or from the Mee factory.



204 West Pomona Ave.  
 Monrovia, CA 91016  
 www.meefog.com

# MeeFog Design Guide

Copyright 2006 Mee Ind. Inc. Proprietary information, do not copy or distribute without prior permission. Subject to change without notice. Mee disclaims liability of any type arising from the use of this information

**DG-H100**  
 September 1, 2007  
 Version: 1.4

## Application Manual For MeeFog Humidification Systems

### 1.0 The MeeFog Humidification Process

MeeFog systems are evaporative humidification systems. When the fog evaporates, the air is both humidified and cooled. It is necessary to have sufficient heat in the supply air to account for the evaporative cooling effect. If the supply air is too cool, it may not be able to hold enough moisture to attain the humidity set point in the conditioned space. HVAC applications that utilize economizer cycle air handlers can modulate the mixture of outside air and return air to maintain the desired discharge temperature; typically, without the addition of supplemental heat.

In-Plant systems evaporate the moisture at or near the ceiling line and the cooler, humidified air gradually falls towards the plant floor, creating natural circulation. This circulation can reduce the heating loads and provide supplemental cooling for the comfort of employees working on the plant floor.

### 1.1 MeeFog Nozzles

At an operating pressure of 1000 psi, MeeFog Nozzles (figure 1) have an output of 16 pounds per hour (lb/hr) or 0.032 gpm.

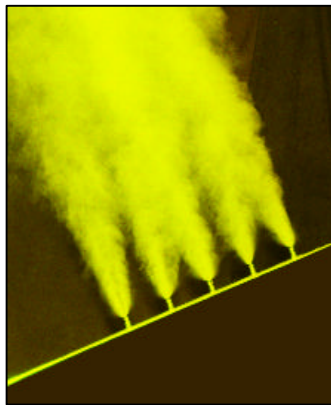

**Figure 1 – MeeFog Nozzle at 1000 PSI**

MeeFog SwirlJet Nozzles applied to in-plant industrial applications have an output of 7 pounds per hour (lb/hr) or 0.015 gpm (figure 2).



**Figure 2 ~ SwirlJet Nozzles**

Ninety-percent of the water output from the nozzles is in droplets that are equal to, or smaller than, about 25 microns in diameter—about one-fourth the size of a single strand of hair. The average droplet size is 5 microns.

### 1.2 MeeFog Humidification Systems

A typical Mee Fog system consists of manifolds of high-pressure nozzles supplied with 1000 psi high pressure water delivered by a high-pressure pump through stainless steel tubing.

The water quality is determined by the application and the quality of the source water supplied to the Mee Fog System. In general, in-space or in-plant systems can use potable water that has been filtered to remove the solids. When the water evaporates the minerals that were in the water remain behind and will precipitate mineral dust in the space. If the mineral dust is objectionable to the process, then further water treatment is required. A reverse osmosis system can be installed to remove 95-98% of the dissolved minerals and solids.

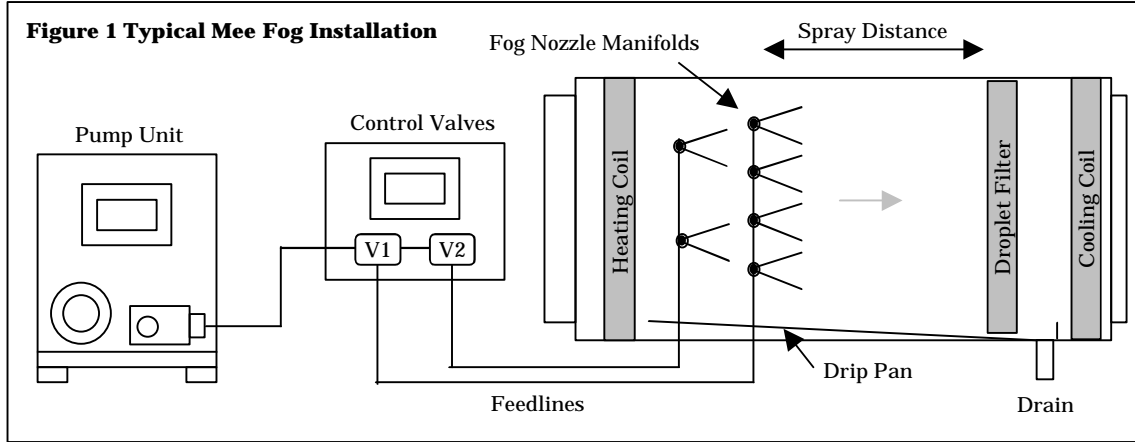

Figure 4 – Typical HVAC System

This purified water will not leave any mineral dust behind when it evaporates.

Mee Fog HVAC applications will have nozzle headers installed directly in the HVAC unit or a duct section down stream of the HVAC unit. The nozzle headers are staged on and off using high pressure solenoids or motor operated valves for capacity control. Each valve is typically connected to a different number of nozzles so the capacity of the system can be controlled over a wide range. All HVAC systems require water treatment using an RO system.

Make-Up air units require more stages of control. On single unit applications, the pump can be fitted with a VFD to vary the pressure to the nozzle headers and thus match the output to the load more closely.

A Fog Droplet Filter is installed down-stream of the nozzle manifolds, Figure 5. Any fog droplets that do not evaporate in the humidification section are captured on the droplet filter and drained away, thus ensuring that no fog droplets can travel downstream of the humidification section. Some types of cooling coils can be used as droplet eliminators.

Figure 4 shows a typical MeeFog humidification system installation in an AHU. This system has two control valves (V1 and V2), which control the fog output. The air pressure drop associated with the nozzle manifolds is virtually zero, but there is a small pressure drop associated with the Fog Droplet Filter.



Figure 3 – MeeFog Nozzle Manifold



Figure 5 – MeeFog Droplet Filters

### 1.3 MeeFog Droplet Filters

Droplet Filters (Figure 5) are made of a special synthetic fiber that is impregnated with an anti-microbial substance to inhibit the growth of mold or bacteria.

The droplet filters are a very effective droplet removal device and can be used at air velocities up to 650 ft/min. At higher air velocities large droplets may be stripped off the back of the filter and can re-enter the air stream.

At air velocities over 200 ft/min the MeeFog Droplet Filters remove virtually all the fog droplets from the air stream. However, at very low air velocities, some droplets may migrate through the filter. For this reason it's usually desirable to have an airflow switch that disables the fog system when the air velocity is less than about 200 feet per minute.

As shown in Figure 4, the distance from the Fog Nozzles to the Droplet Filter is called the Spray Distance. Longer Spray Distances are desirable because more of the fog will evaporate before reaching the Droplet Filter, Figure 7. The air pressure drop across the Droplet Filters is a function of the air velocity and degree of saturation, Figure 6.

It's important to supply clean, well-filtered air to the humidification section. If dust and dirt accumulates on the droplet filters it can inhibit the anti-microbial action of the impregnated fibers. The droplet filter media can be cleaned with soap and water and then rinsed with clean water. If the filter media cannot be cleaned it is easily changed.

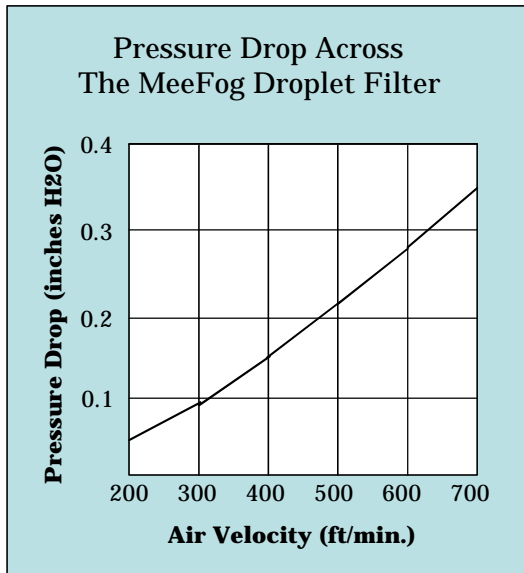

Figure 6 – Droplet Filter Pressure Drop.

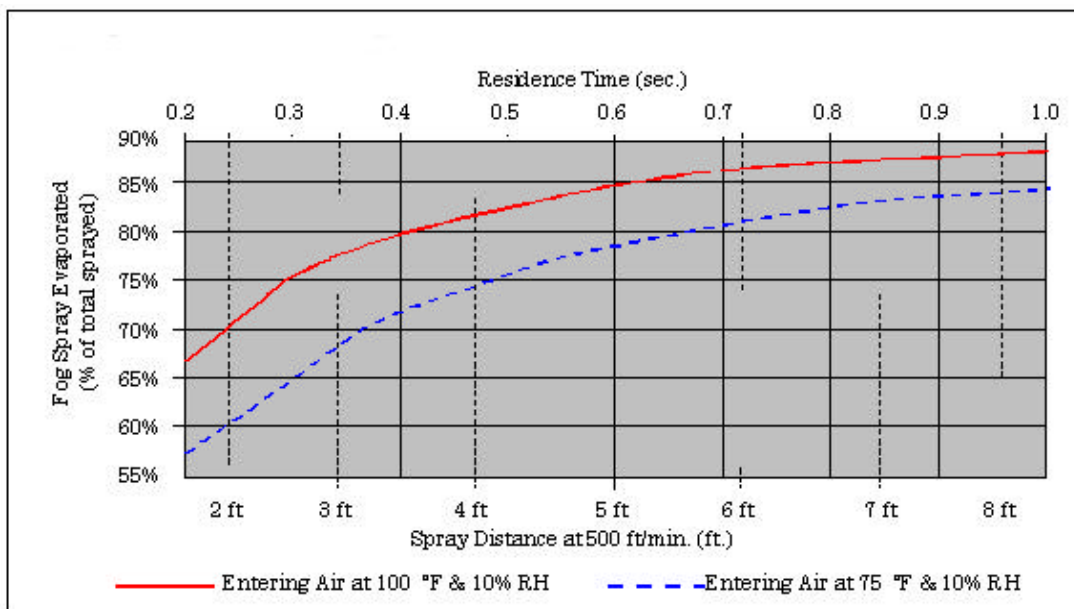

Figure 7 – MeeFog Evaporation Rates.

## 2.0 HVAC Applications

Atomizing type humidification systems have been applied in HVAC systems for some time. The use of Mee Fog high pressure systems in this application is no different than other types of adiabatic systems. Moisture is introduced into the air stream via nozzle headers with the nozzle spacing and number of nozzles determined by the humidification load plus losses. Generally the nozzle headers are placed in a section of the air handler or duct, and provided with a full SS IAQ drain pan. If the section is an integral part of an air handler, then the optimum section location should be determined by MeeFog. Heating and/or cooling coils provide laminar air flow which reduces moisture fallout due to centrifugal forces on the water droplets. Highly turbulent air streams should be avoided, and minimum distances before and after the humidifier section from fittings and transitions should be maintained.

### 2.1 HVAC Nozzle Placement

The nozzles typically used for HVAC applications are the MeeFog IP-16 impaction pin nozzle rated at 16#/hr at 1000 psi (Fig 8).

The nozzles may be fitted with 3" SS extenders to allow aiming the nozzle discharge. (Fig 9)

The nozzle headers should be located near the incoming side of the section with the nozzles oriented in one of several directions.

The nozzles can be directed into the incoming air stream so the moisture has the greatest mixing opportunity with the air as it turns around and flows towards the discharge.

With this arrangement, the nozzle headers will need to be mounted far enough from the front of the section to prevent water from impinging on filters or coils.

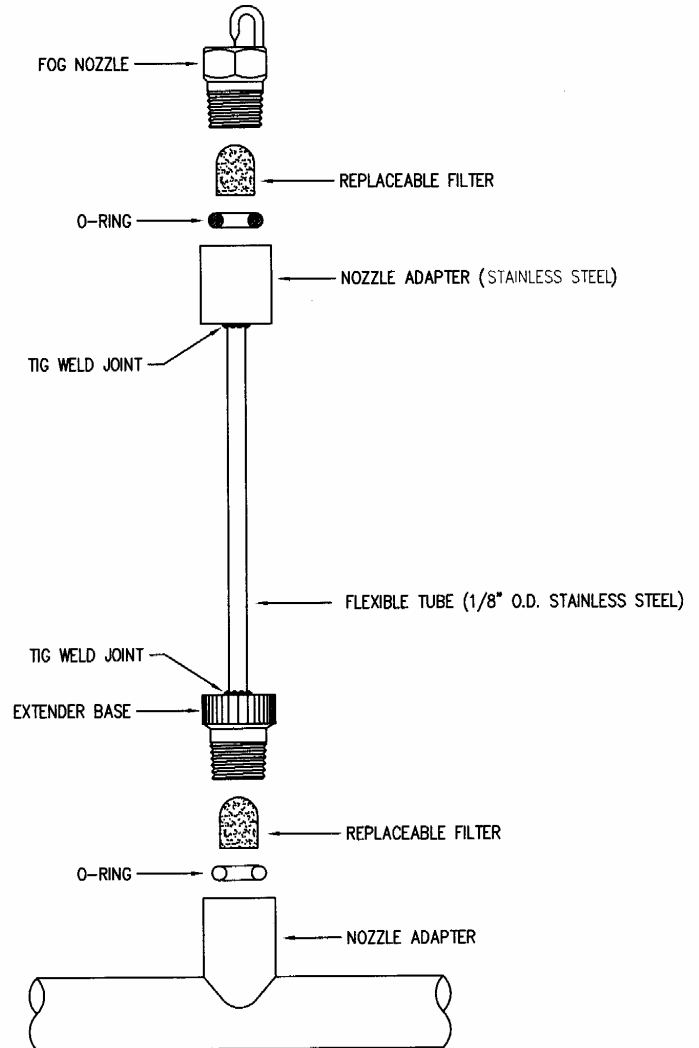

Figure 9 ~ IP-16 With 3" SS Extender

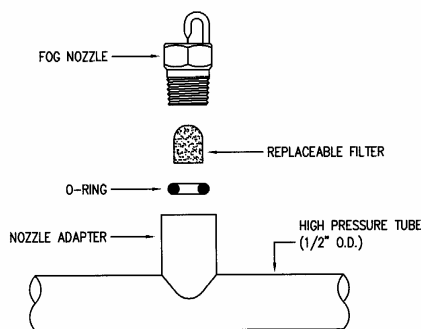

Figure 8 ~ IP-16 Nozzle

This distance is determined by the air velocity and is typically 16" at 500 fpm (Figure 11).

This orientation results in a little more dripping since the moisture hits the nozzle headers as it is carried towards the back of the section. To reduce dripping on shut off, the nozzles can be fitted with anti-drip check valves that will close when the nozzle header is off.

Another arrangement is to point the nozzles at an angle either with the air stream or against it, to increase contact with the air stream while reducing the amount of distance required between the nozzle headers and the front of the section. This orientation reduces contact mixing efficiency of the water with the incoming air stream somewhat but eliminates the dripping caused by the moisture hitting the nozzle headers as it travels towards the back of the section (Figure 12).

Air velocity and air temperature are important parameters used to determine the absorption efficiency of the humidifier system. The lower the air temperature, the less capacity the air has for holding moisture, and the higher the air velocity, the shorter time for absorption before leaving the humidification chamber or impinging on the droplet filter.

Most HVAC systems are designed around mixed air temperatures of 55 F DB or higher and approximately 500 fpm air velocity. If the air is colder than this then consideration must be given to additional losses or lower efficiency. Moisture that has not been absorbed by the time it reaches the discharge of the humidifier section will be collected by the droplet filters. As the efficiency decreases the droplet filter will collect more moisture and take it to drain. MeeFog has empirical curves that will assist in determining the absorption efficiency for any particular combination of parameters (Appendix C).

## 2.2 HVAC Nozzle Header Location

Nozzle header arrangements should follow the following physical guidelines (figure 10):

- The first and last nozzle on each header should be approximately 8-12" from the sides of the chamber.
- The top and bottom header should be approximately 8-12" from the top and bottom of the chamber.
- The spacing between adjacent nozzles and adjacent headers should be a minimum of 8", and should be evenly spaced vertically and horizontally so the moisture will be dispersed across the section.
- The nozzle headers connected to a common stage should be separated from each other vertically to spread out the moisture that is introduced into the air.
- The nozzle headers should be located so any dripping from the headers will fall into the drain pan.
- The humidifier section should be constructed so there are no obstructions in the path of the moisture to cause dripping or condensation. This can typically occur in duct sections that have bracing to stiffen the duct section.

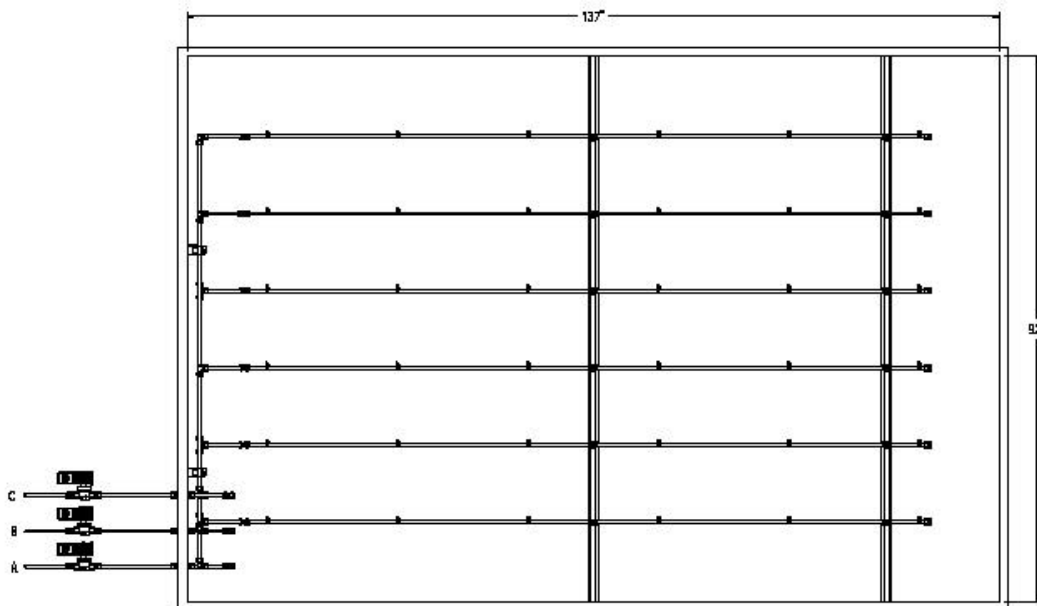
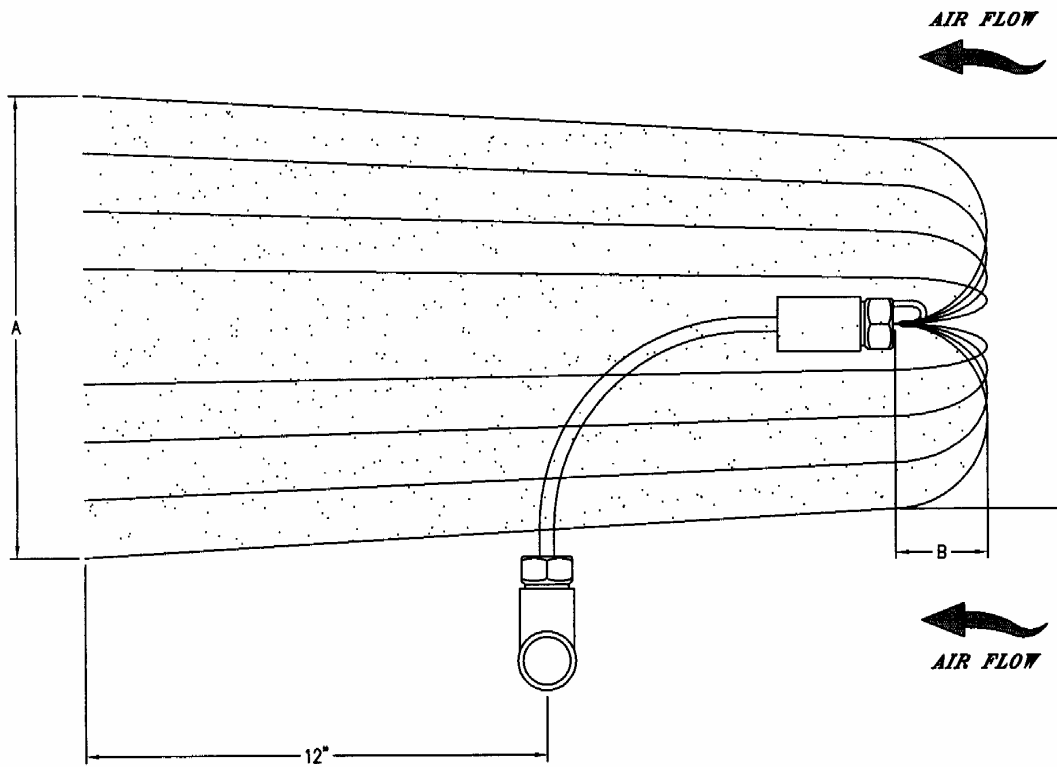

Figure 10 ~ Nozzle Header Arrangement



AIR VELOCITY Ft. / Min.	250 PSI			500 PSI			750 PSI			1000 PSI		
	A	B	C	A	B	C	A	B	C	A	B	C
400	11	4	4	14	9	9	16	10	10	16	14	12
600	11	2	4	12	6	7	16	8	10	16	10	12
800	9	1.5	3	11.5	5	5.5	14	6	8	15	7	9
1000	8	1.5	3	11	4	5	13	5.5	8	15	6	8
1200	7.5	1	2.5	9	4	4	12	5	7	14	6	8

ALL DIMENSIONS IN INCHES

Figure 11 ~ IP-16 Nozzle Pointed Directly Into Air Stream

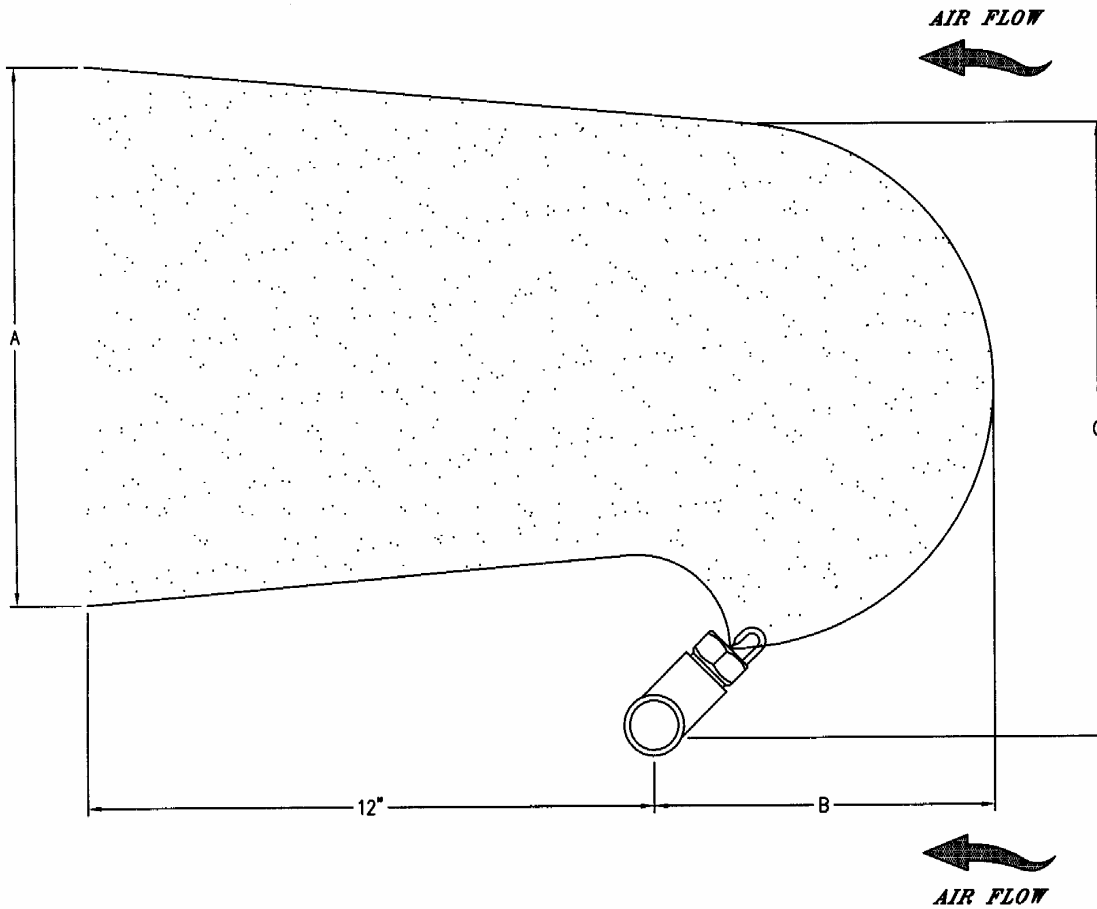

AIR VELOCITY Ft. / Min.	250 PSI			500 PSI			750 PSI			1000 PSI		
	A	B	C	A	B	C	A	B	C	A	B	C
400	10	2	3	11	1.75	6	12	2.5	7	12	3	9
600	9	1.75	2.5	9	1.5	3.5	11	1.5	6	12	2.5	9
800	8.5	1.75	2	9	1.5	3.5	10.5	1.5	5	10	2	7
1000	8	1.75	2	9	1.25	3.5	10.5	1.25	4	9.5	1.5	5
1200	7	1	2	9	1.25	3.5	10	1.25	4	9	1.5	4

ALL DIMENSIONS IN INCHES

Figure 12 ~ IP-16 Nozzle Pointed At 45° Into Air Stream

## 2.3 Evaporation Efficiency

Evaporation Efficiency is defined as the percentage of the fog spray that evaporates before being captured on the Droplet Filter, Figure 7.

For example, 80% Evaporation Efficiency means that 80% of the fog spray evaporated and entered the air-stream, while 20% was captured on the Droplet Filter and drained away. The un-evaporated water must be taken into account when designing a fog system.

Evaporation Efficiency depends on many factors including the residence time of the fog droplets in the air stream, the size of the droplets, the relative humidity and temperature of the air, and the temperature of the water.

## 2.4 Determining the MeeFog Nozzles Required

Figure 13 shows a typical commercial HVAC system and the calculation for determining how many fog nozzles will be required to maintain 72°F and 50% RH in the space.

Figure 7 can be used to find how much water will evaporate for a given system design. The spray distance and the airflow velocity determine the average residence time; as shown in the formula.

$$\frac{\text{Spray Distance (ft.)}}{\text{Air Velocity (ft./sec.)}} = \text{Residence Time (sec.)}$$

For convenience, the spray distance is given in Figure 13 for an air velocity of 500 ft/min., the typical air velocity in AHUs.

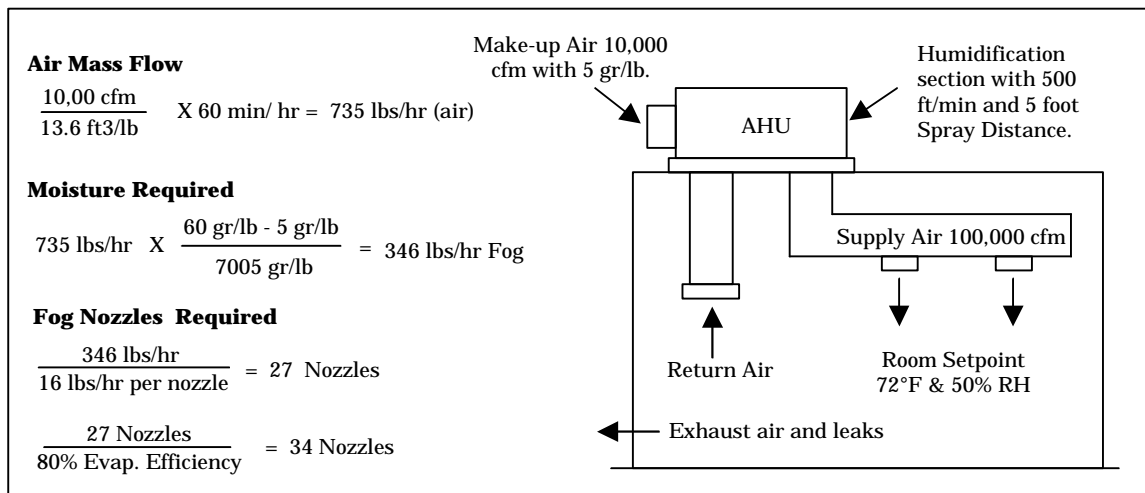

**Figure 13 ~ Determining Number Of Nozzles Required**

## 2.5 Controlling Fog System Output- HVAC

High pressure valves are often used to modulate the output of MeeFog Systems. The operating pressure of the fog pump is kept constant (usually at 1000 psi) and valves are opened and closed as needed to maintain the humidity set point in the treated space.

This staged-control method can give very precise control of the humidity level in the air duct. Tight control can be accomplished by using a number of valves, each supplying water to a different number of nozzles, and controlling those valves in the proper sequence to get many stages of fog output.

Figure 14 gives an example of stage-control, and the valve switching sequence, for three valves giving six stages of output.

Stage	Valve 1 (1 nozzle)	Valve 2 (2 nozzles)	Valve 3 (3 nozzles)	Nozzles operating
1	Open	Closed	Closed	1
2	Closed	Open	Closed	2
3	Closed	Closed	Open	3
4	Open	Closed	Open	4
5	Closed	Open	Open	5
6	Open	Open	Open	6

**Figure 14 - Six Stages of Fog Output with Three Valves.**

## 2.6 Determining the Control Increment for Different After-Fogging Temperatures

The Control Increment is the increase, or decrease, in humidity in the duct associated with each stage of output. The Control Increment shown on the chart (Figure 16) is for applications with make-up moisture of 55 grains per pound (55 g/lb) and an after fogging temperature of 72°F.

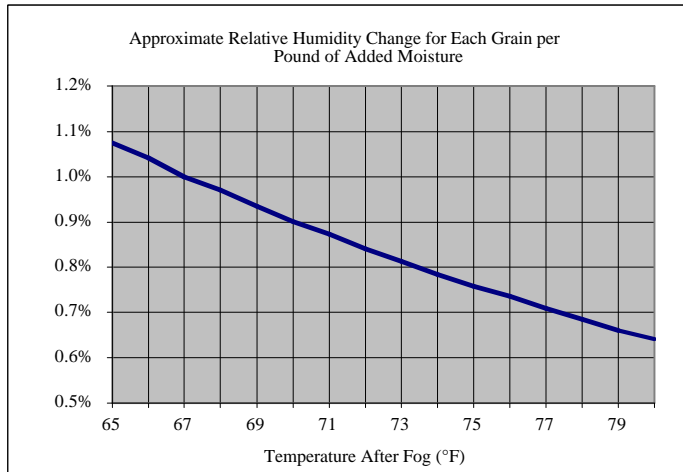

**Figure 15 - Relative Humidity Change per Grain of Moisture Added**

The chart (Figure 16) is based on the fact that, with an after-fogging temperature of 72°F, adding one grain of moisture to one pound of air (1 gr/lb) will result in an increase of about 0.85% RH.

Figure 15 shows the change in RH for each gr/lb of moisture added over a range of temperatures. When using this chart consider the temperature of the treated space, not the supply air temperature.

## 2.7 Determining How Many Stages Are Required For HVAC Applications

The number of stages required for a particular fog system depends on the air-change rate and the desired maximum fluctuation (over time) of the humidity level in the treated space.

For a typical commercial or industrial building a humidity fluctuation of +/- 5% RH is generally considered acceptable.

Clean rooms and high-tech manufacturing or research facilities may require accurate control of humidity to +/- 1% RH.

Air-change rate is an important factor to consider when designing a stage-controlled fog system. If the air-

change rate is low, as it is in a typical commercial or industrial building, then a few stages of fog give very precise control; because even if the air leaving the AHU has a high level of humidity, it will take some time for the treated space humidity to come up to set point. Slow air change rates have a dampening effect on fluctuations in the treated space humidity level, as shown in figure 17.

When designing a fog system, keep in mind that the moisture content of the air entering the humidification section is usually relatively steady, and if the dead-band in the humidity sensor is bigger than the staging increment, the system will find a sweet-spot and hold at one staging level for an extended period of time.

Figure 17 shows that three stages of fog output in a space that has ten minutes per air change will result in a humidity fluctuation of about 1.5% RH per minute. If the maximum desired humidity fluctuation is +/- 5% RH (a total of 10% RH) then the staging valve would have to be actuated approximately every 7 minutes in order to maintain the desired humidity fluctuation.

Figure 17 also shows that a space with one minute per air change and 31 stages of fog (which requires 5 valves) would also have a humidity fluctuation of about 1.5% RH per minute. In order to maintain +/- 1% RH in this space, the valve may have to be actuated as often as once per minute. Typically using three valves, which give six stages of control, results in a system that is more than adequate for a commercial or industrial building. While facilities that have very high air change rates might require as many as 5 valves (giving 31 stages) to attain humidity control of plus-or-minus 1% RH.

Make-up Air Units, which feed pre-humidified air to other AHUs, may also require control as precise as +/- 1% RH. But it is unusual for an application to require more than five solenoid valves.

## 2.8 Automatic Control of Staging Valves HVAC

The solenoid valves can be controlled directly by a Building Automation Computer (BAC), or they can be controlled by a MeeFog Controller, or by a combination of both. The last option is the most common; the BAC provides a humidity demand signal to the MeeFog Controller and the Controller manages the sequencing of the valves.

More information on designing control systems, see MeeFog Design Guide DG-H101, "Control Schemes for MeeFog System", Appendix B.

Solenoid Valves (qty)	Nozzles Per Valve (Actual nozzles can be any multiple of numbers shown)					Total Stages (qty)	Control Increment	
	V1	V2	V3	V4	V5		gr/lb	RH% +/-
2	1	2				3	17	7.3%
3	1	2	4			7	7.1	3.1%
4	1	2	4	8		15	3.3	1.5%
5	1	2	4	8	16	31	1.6	0.7%

Note: Control Increment assumes 50 gr/lb of moisture added at 72°F in the treated space.

**Figure 16 - Stages and Control Increments.**

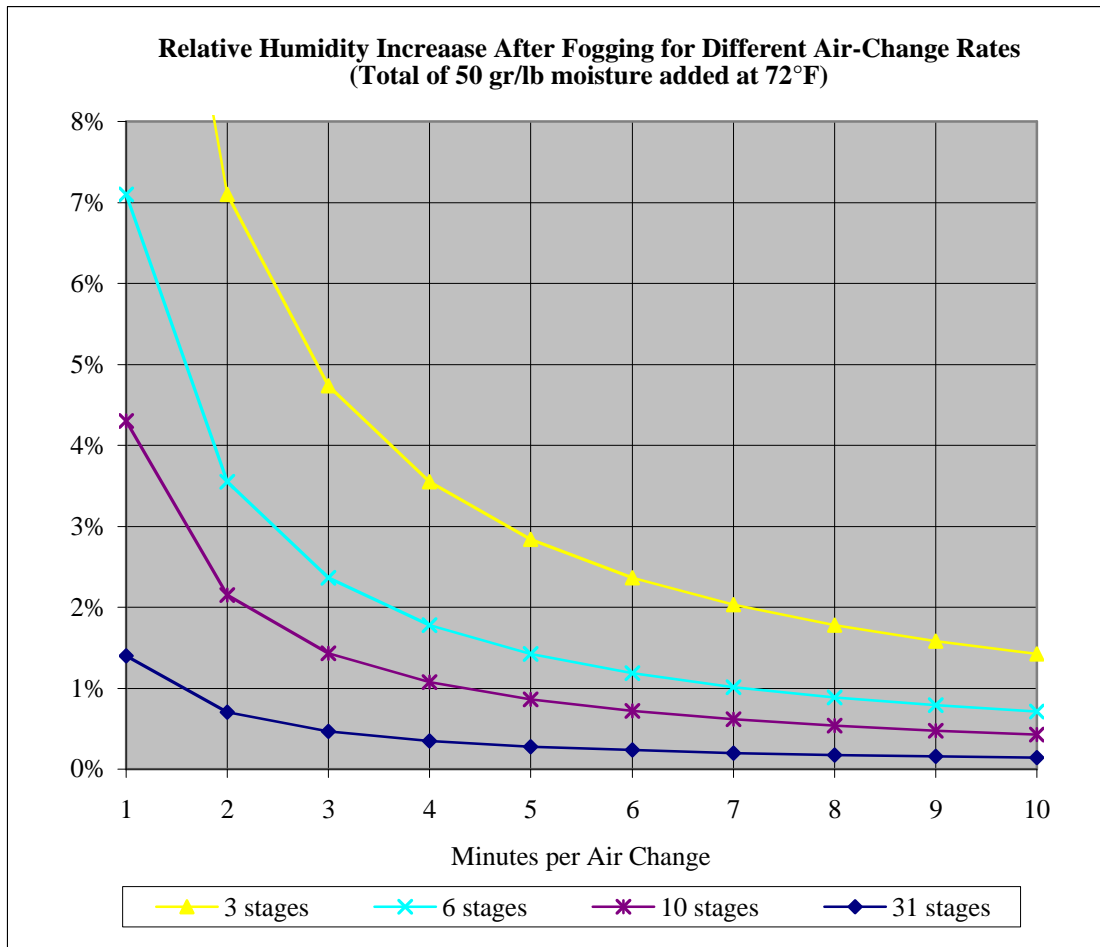

**Figure 17 - Affect of Air-Change Rate on RH fluctuation.**

On HVAC applications where Mee Fog is providing the controls, a PLC or Staging Humidity Controller is used to control the staging of the nozzle headers. The return air or space humidity is measured by a sensor and this value will control how many stages are on at any given moment.

A high limit sensor is installed in the discharge duct to monitor the leaving humidity level. If the discharge humidity exceeds the high limit setting, the Controller removes a stage to reduce capacity. The Controller constantly monitors the humidity level and adds or removes stages as necessary to stay within the humidity tolerance band. Multiple air handling units can be controlled by a single PLC system.

Humidifier capacity is controlled by turning on or off the various nozzle headers. The headers are typically arranged in 1/3, 2/3, 3/3 or 1/6, 2/6, 3/6 or 1/7, 2/7, 4/7 configurations with a solenoid valve on each stage. In this manner, 3, 6 or 7 stages of capacity can be derived from just 2 or 3 solenoids. On 100% outdoor applications, a fourth solenoid can be used to get to 15 stage capacity control to follow the moisture load much closer. Figure 10 shows the header and solenoid valve arrangement for a 1/6, 2/6, 3/6 staging control.

Solenoid "A" is connected to a single header, Solenoid "B" is connected to two headers, and solenoid "C" is connected to three headers.

On control systems supplied by others, such as BAS systems, the Mee System is controlled by relay contact inputs to the solenoid panels. A contact is required for each zone/stage plus a contact at the pump control panel to start the pump. Alarm contacts for remote signaling should be designated during the project layout and specification.

### 3.0 In-space Applications

In-space systems are generally used for large industrial plants with large open spaces and that may have little or no forced ventilation capability. The nozzle headers are located near the ceiling where the air is warmer and has a higher capacity for moisture. The nozzle headers are located near the ceiling where the air is warmer and has a higher capacity for moisture. The air around the nozzles is cooled as the moisture is absorbed and subsequently falls towards the floor. This cooler air is then replaced with warmer dryer air from below which creates a natural circulation in the plant.

### 3.1 In-Space Nozzles

The nozzles typically used for in-space applications are the SJ-7 swirl jet nozzle rated 7#/hr at 1000 psi. The nozzles are fitted with an integral filter and check valve to eliminate dripping when the zone is turned off. (Figure 18). The nozzles are typically fitted with a 3" SS extender so the nozzle orientation can be adjusted on installation. The extender has an integral filter also. (Figure 19)

### 3.2 In-Space Nozzle Header Installation

The nozzle headers are suspended on all thread with plastic clics or on hydrasorb fittings and unistrut channel. The nozzle headers and high pressure feed line are all constructed of SS tubing with compression fittings.

The nozzle spacing and header locations are determined by the humidity load and the arrangement of the space. The headers are generally located over aisle ways for ease of installation and future maintenance.

Control of the humidity level is accomplished by sensors that control high pressure zone solenoids or motor operated valves. As each zone is satisfied, the zone valve closes and the pressure relief valve opens to relieve the pressure on the zone headers, allowing the nozzle check valves to close. (figure 20)

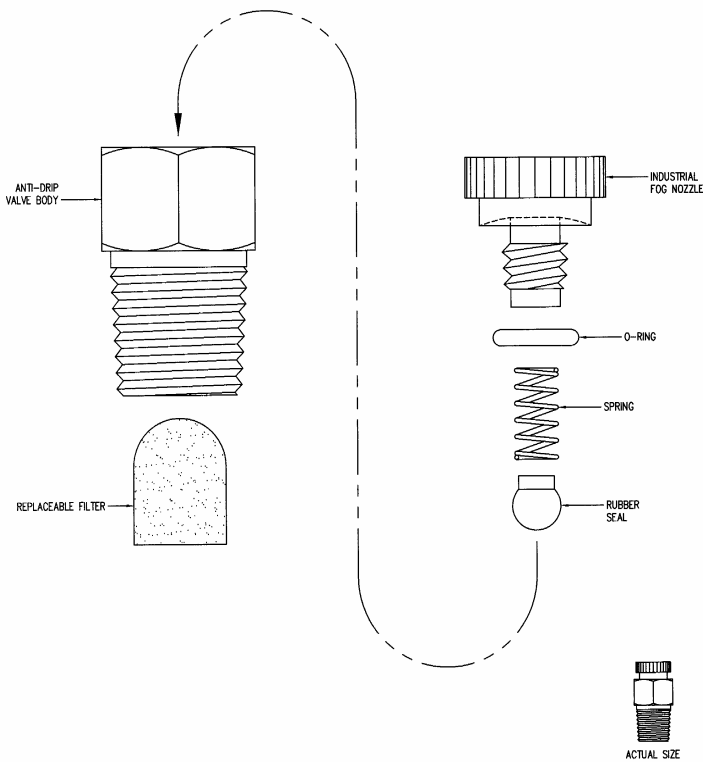

Figure 18 ~ SJ-7 SwirlJet Nozzle With Anti-Drip Check Valve

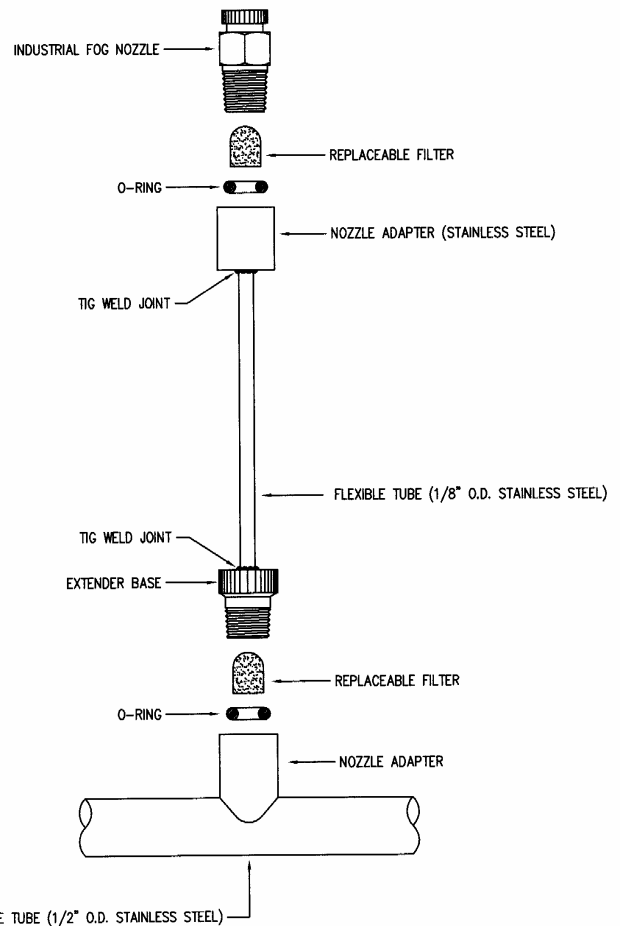

Figure 19 ~ SwirlJet SJ-7 Nozzle With 3" SS Extender And Anti-Drip

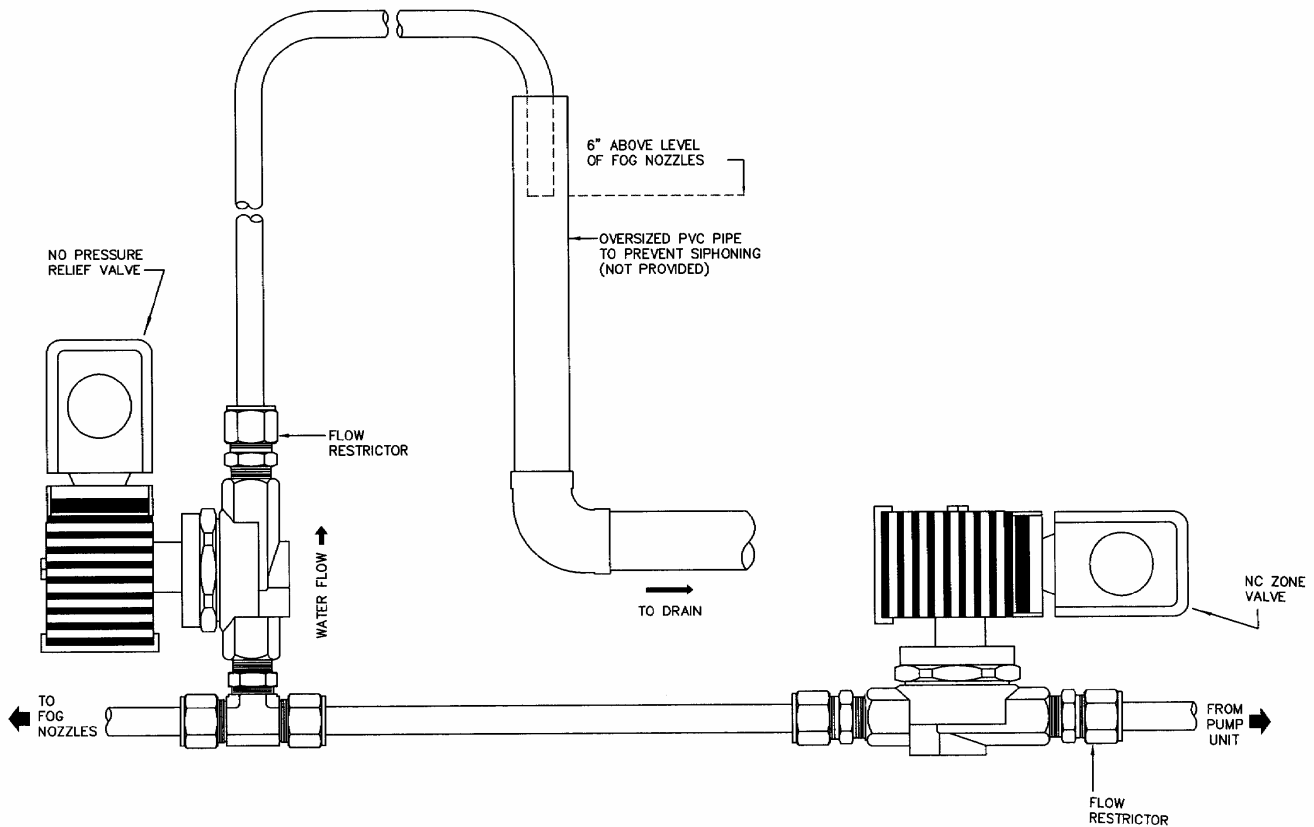

Figure 20 ~ Zone Solenoid With Pressure Relief Dump Solenoid Arrangement

### 3.3 Automatic Control of Zone Valves

The control system can be furnished by Mee Fog or by others. Each system can be unique to the facility or can utilize one of Mee Fog’s standard systems. The number of different configurations is endless so just the standard Mee Fog methods will be discussed here.

The Mee Fog FogStat is a two zone humidity controller with the capabilities of controlling the humidity or temperature of two zones as well as having night set back and outdoor temperature sensor set back features. The space sensors are generally located central to each zone. Each sensor is provided with 3/C #20 shielded cable for connection to the FogStat.

The zones are on humidity differential from setpoint and will start the pump when the humidity level in the space falls to the set point and shut the pump off when it reaches the set point plus differential. Multiple FogStats can be assembled on each system. The FogStat manual is available from the factory.

In addition to the space sensor, each zone has a high limit humidistat that will lock out the pump when tripped. The high limit setting is adjustable at each high limit controller. The high limit controller requires 4/C #18 low voltage cable back to the pump control panel. This cable is not provided with the system.

### 4.0 System Configuration

#### 4.1 Humidification System Packaging

The humidifiers are packaged in different ways depending on the type of system. Normally the nozzle headers and feed line will ship in 20’ long boxes separate from the pump and control panel packaging. The pump and control panels will ship in plywood crates with the panels and pumps bolted to the bottom and/or sides of the crate. Inspect the shipment immediately for damage or missing items. All shipping damage and missing items must be reported to the shipping company within five business days from the date received.

## **4.2 Maximum Number of Nozzles Per Valve**

MeeFog Solenoid Valves can supply water flow for up to 60 IP-16 fog nozzles, while Motorized Ball Valves can be used to control up to 200 IP-16 Nozzles. Solenoid valves can control approximately 130 SwirlJet SJ-7 Nozzles and Motorized Ball Valves can control in excess of 300 SJ-7 Nozzles. Solenoid Valves can be actuated as often as once per minute, for pulsed control of the fog system output.

It's recommended that motorized ball valves not be actuated more frequently than once every five minutes, to reduce the maintenance interval for the valve-stem packing.

## **4.3 Layout and Installation**

The exact sizes of control panels, nozzle headers, and other components will be determined at the time of system configuration and design by Mee Fog. Detailed system information will be contained in the submittal information and/or O&M Manual for a particular job. The information contained herein is a general guide for systems. These sizes may change depending upon the particular application. Refer to the submittal or information package sent with each individual job for exact details.

## **4.4 Control Panel Sizes**

Control panel sizes are based on the type of control as well as the number and type of control zones/stages required. Mee Fog uses standard size back plates for mounting the various control panels, FogStats and zone or staging solenoids. The back plates are either 18" high by 26" wide or 34" wide. These back plates are used for all of the various control assemblies.

## **4.5 Humidifier Dimensions**

Each Mee Fog system is custom designed for the particular project at hand. Nozzle header dimensions are determined by the humidity load and space or HVAC arrangement.

## **5.0 Pumping Systems**

The Mee Fog high pressure pumping systems consist of a water inlet panel, pump control panel and high pressure pump unit or some combination of panels. The water inlet panel filters the water through high efficiency cartridge filters down to 0.35 microns

absolute. The water is filtered to remove any dissolved solids that would plug the nozzle orifices. The filter cartridge change out frequency will be determined by the quality of the incoming water supply and water usage. The water inlet panel has a low pressure solenoid to control the flow of water to the pump inlet. When the pump starts, the solenoid opens and a supply water pressure switch checks to make sure there is enough water pressure to operate the pump. If the water pressure is low or non-existent, the pressure switch will time out and shut the pump down.

This will protect the pump in the event the supply is shut off or the inlet filters are plugged.

The water is sent to the pump inlet via low pressure hose(s). The high pressure pump discharge is directed to the high pressure distribution system via a high pressure hose. The pump discharge has a pressure switch that monitors the pressure and will time out and shut the pump off on a discharge pressure less than 850#.

The pump is controlled from the pump control panel. This panel can be as simple as a constant speed starter (Fig 21) or as complex as a variable speed drive controlled by a discharge pressure transducer or proportional signal from the humidity control system (Fig 22). Many systems can benefit from the use of a variable speed drive on the pump that will reduce the energy used and the wear on the pump.

On systems where the high pressure pump supplies water to multiple zones or HVAC systems, the pump is configured to run only as fast as necessary to maintain the design discharge pressure of 1000 psi. In this manner, as the loads vary so will the pump speed.

## **5.1 Pump Cooling**

The pump discharge pressure is regulated by a high pressure bypass regulator on the pump discharge. Excess relief water is either directed back to the pump inlet or to a storage tank or drain connection. Excessive recirculation back to the pump inlet can cause pump over heating and is to be avoided. The pump requires a minimum of 20% fresh water for cooling. On applications without an available water storage tank, the use of a pump cooler is recommended.

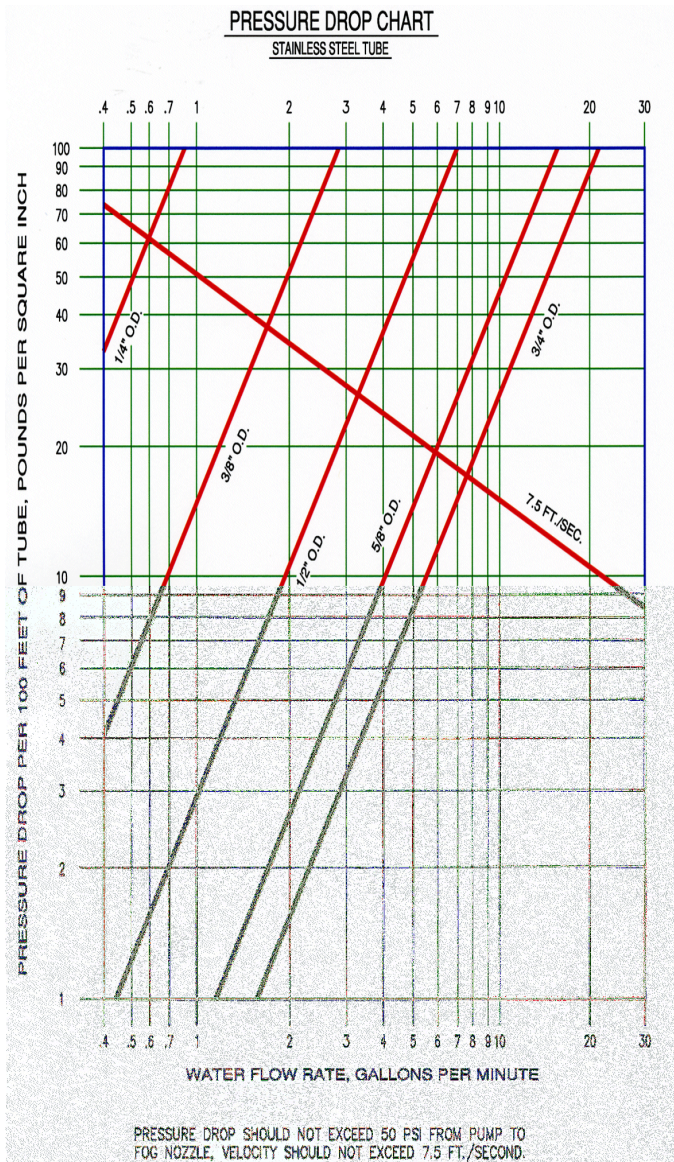

Figure 23 Tubing Pressure Drop

## 5.2 Piping Requirements

The low pressure inlet water piping should be of a material compatible with the quality of water being supplied to the system. Filtered tap water can be supplied using schedule 80 PVC or copper piping. If the water has been processed through an RO system then the piping material should be limited to PVC or 304/316 grade stainless steel. If the inlet water has been processed through an RO/DI water treatment system then the inlet piping material should be limited to Grade 316 stainless steel or Schedule 80 PVC.

The high pressure discharge piping or tubing is designed to contain the 1000 psi high pressure water plus a safety factor. The standard tubing provided by

Mee Fog is stainless steel grade 304 or 316, 0.035" wall thickness with welded seams. The tubing connections are double ferrule compression fittings. The tubing runs are designed for a maximum of 50 psi pressure drop to the nozzle headers. On large zones it may be necessary to use 3/4" OD SS tubing to reduce pressure drop on the main feed line runs. The Mee Fog engineering department will make that determination and include the correct tubing and fittings in the equipment package.

## 5.3 Water Requirements

The high pressure pump **must** be supplied with filtered and softened water or RO (*Reverse Osmosis*) water. The treated and/or filtered water should only be carried in PVC or stainless steel piping. D.I. water cannot be used on in-space applications. The high resistance of D.I. water creates static charges on the nozzle tips and attracts water droplets, which subsequently drip. D.I. water can be used with the HVAC systems if it is designed for at the start of the project. Mee Fog high pressure pumps may be provided with brass housings and brass fittings which cannot be used with D.I. water. If D.I. water is to be used then the factory must be notified at the start of the project.

Consideration should also be given to the inlet pressure as well. It is recommended that the inlet water pressure be not higher than 60 psi or lower than 30 psi. If the inlet pressure is higher than 60 psi, the pressure can lift the pump pressure relief valve to relieve the pressure. Damage to the high pressure pump can occur.

## 5.4 Water Treatment Systems

The use of water filtered through a Reverse Osmosis system (RO) is recommended for all MeeFog systems. The removal of minerals and dissolved solids from the supply water will reduce routine maintenance and extend the time between filter changes.

A typical RO system will comprise carbon pre-filters, water softeners, RO unit, storage and/or re-pressurization pump and UV light. A typical RO system is shown on Figure 24. MeeFog can size the proper water treatment system for each project. MeeFog has a complete water analysis laboratory to analyze water samples supplied by customers. Water treatment systems provided by MeeFog will be sized correctly and will provide the proper amount and quality of water required for the project.



## 6.0 Installation Guidelines

### 6.1 Design Limitations

The design of the Mee Fog high pressure humidification system is based on certain parameters or conditions. These conditions must be met for the proper operation of the system.

In HVAC applications the requirements are as follows:

- 300 - 650 feet per minute air stream velocity
- 50 - 125° F supply air temperature
- Minimum of 36" absorption distance

In In-space applications the requirements are as follows:

- 34 - 125° F air temperature
- Minimum 14' ceiling height

The minimum requirements for the supply water are as follows:

- 30 - 60 psi supply water pressure
- 40 - 100° F supply water temperature
- Filtered with 0.35 micron absolute filter
- Softened if hardness is greater than 6 grains

### 6.2 Material Storage and Handling

It cannot be stressed too strongly that the equipment and hardware should be stored and handled in such a manner as to keep it clean and free from construction debris. The equipment and tubing is shipped clean, and every effort should be made to keep it that way. Dirt that enters the tubing and fittings will eventually end up at the nozzles and can cause pre-mature plugging and improper operation. The system will be flushed before start-up so keeping it clean during installation will reduce the flushing effort.

### 6.3 Installation Methods

Compression couplings are provided for connecting the 20 foot sections of tubing, but no fittings are provided for transitions or off-sets. The use of compression fittings for bends or offsets should be avoided to reduce water hammer in the piping system. A standard ½" tubing bender with a 4" minimum radius of bend should be used on all field bends. Every effort should

be made to use field bends on the tubing rather than fittings. Properly installed compression fittings are very reliable.

The compression fittings should be installed as follows:

1. Loosen the fitting nut
2. Firmly insert the tubing into the fitting assembly. Proper insertion requires that the tubing be fully bottomed out in the fitting body.
3. Finger tighten the nut.
4. Mark the nut at the 12:00 position.
5. While holding the body of the fitting with a backup wrench, further tighten the nut with a wrench 1-1/4 turns by going completely around past the 12:00 position to the 3:00 position.
6. On tubing smaller than ½" OD consult manufacturer's instructions regarding tightening.

### 6.4 In-Space Systems

The nozzle feed line and header tubing should be installed level and supported every 4-5 feet using "Clic" tubing fasteners or hydrasorb unistrut clamps. Every support fitting used on the tubing should be a cushion grip or plastic Clic type fitting to prevent friction between the tubing and any other metal surface. The proper type of support fitting will allow some movement of the tubing and prevent degradation of the tubing wall. If the tubing is supported on all thread rod then the rod length should be kept as short as possible, 6-12" is an optimum length. Long all thread hangers increase the opportunity for tubing movement during ON/OFF operation.

Support the tubing so there is adequate clearance between the tubing and adjacent structures or obstructions, allowing for some tubing movement during normal operation. The nozzle headers should be installed with the nozzle adaptor "T" oriented vertically. This increases the migration of trapped air through the tubing and out the nozzle adaptors.

Do not use any type of thread or anti-seize compound on any threaded connections. Compound will find its way into the nozzles and cause plugging.

If thread lubricant is needed, the use of Teflon tape is acceptable on NPT fittings only.

Do not use any type of thread lubricant, anti-seize compound or Teflon tape on compression fittings or O-Ring connections.

All solenoids will be provided with orifice fittings that should be installed on the discharge side of the solenoid. The orifice fittings look just like a typical compression/threaded adaptor except the threaded end is solid with a small hole drilled in it and the fitting is dyed red. This small hole limits the volume and velocity of water that can flow through the valve and reduces water hammer and movement of the nozzle lines. The orifice fittings are dyed red for identification and visual inspection during and after installation.

Nozzle and extender fittings are o-ring connections. The nozzle o-ring should be inserted into the open end of the extender, and the nozzle should be tightened down on the o-ring hand tight and then a quarter turn with a 3-4" wrench. The extender connection to the nozzle header is similar, with the o-ring inserted into the nozzle adaptor "T" on the header and the extender tightened down on the o-ring. Over tightening of the o-ring fittings will destroy the o-rings and result in improper operation of the nozzles. No thread lubricant of any kind is to be used on these fittings. After the extender is installed pointing straight up, bend the tubing to aim the nozzle in the proper direction so the spray will not impinge on anything. Place a supporting finger on the threaded portion of the extender where it is screwed into the adaptor and using your thumb, bend the extender forward.

In-space systems will be provided with normally open pressure relief solenoids, referred to as dump valves, as well as with zone solenoids that are normally closed valves. The dump valves are to be installed down stream of the zone supply solenoids and vented to a drain. Refer to the standard Mee Fog detail (figure 20) for the proper installation of the dump valves.

The gooseneck tubing arrangement is important. The gooseneck should be a smooth bend and should be inserted into the drain piping at least 6" to prevent back splashing of the pressure relief water. If there are several dump valves in close proximity, they can all be dumped into a common drain line.

Zone and dump solenoids are supplied as 120 volt or 24 volt, with the standard being 120 volt. The supply wiring to each solenoid should be #16 AWG minimum. The common of each zone and dump pair can be combined to reduce field wiring.

## 6.5 HVAC Systems

HVAC systems are provided with supply solenoids for each stage for capacity control. The supply solenoids can be located at the pump panel or remotely at the air handler. The remote solenoid panels are the interface to the control system. Each stage will require a contact from the BAS system, if control is by others, otherwise if the solenoids will be controlled by the Mee Fog Controller.

The nozzle headers are typically connected in steps for capacity control. Refer to the nozzle header drawing provided with the system for the correct connection pattern. It is important to connect the headers in the correct sequence to the staging solenoid valves.

The remote solenoid panel is wired so the solenoid closest to the panel is #1, with the numbers increasing as the distance from the panel increases. The nozzle headers are identified with the number of the solenoid they are to be connected to. Space the nozzle headers as evenly as possible vertically and horizontally in the air handler. The headers will be mounted on the SS strut provided, and mounted using the strut cushion brackets also provided. The SS strut should be installed so the nozzle headers are as close to the beginning of the humidification section as possible. The high pressure feed lines coming into the air handler from the solenoid panels are to be installed using the bulk head fittings provided. It is important that the SS tubing does not rub on the opening going through the side of the air handler. If the nozzle headers are to be installed in a duct section, the humidifier duct section should be at least 4 duct widths from a large transition or elbow and the same on the discharge of the section.

If the SS extender is not included, the nozzle header should be installed with the nozzle adaptor "T" facing up at a 45° angle into the incoming air stream. On installations with extenders, the nozzle headers should be installed so the nozzle adaptor "T" is facing up. After installing the extender, hand bend the extender to the desired nozzle orientation. Care should be used to not kink the extender. Place a supporting finger on the threaded portion of the extender where it is screwed into the adaptor and using your thumb, bend the extender forward.

## 6.6 Droplet Filters

The droplet filter is constructed of 25" wide filter panels with SS frames and mesh to support the filter media. The media is a synthetic material treated to reduce microbial growth and meet code related fire spread requirements. The filters are furnished with SS angles to support the frames. The droplet filters are custom designed for each air handler with the last section having an adjustable width to provide a precise fit (figure 18). This panel can be trimmed to fit the air handler width and the loose side frame can then be installed on the panel. SS angle is provided for installation on the sides and top of the air handler to support the droplet filter panels. The panels should be screwed to the SS angles using SS Tek screws. SS "T" bars are also provided for installation between the filter panels. The "T" bars should also be screwed to the panel frames using SS Tek screws. The droplet filter panels should be supported horizontally approximately 12" from the bottom with SS unistrut or SS angle.

The droplet filter panels should not be resting on the bottom of the drain pan. There should be a 1/2" air gap between the bottom of the panel and the drain pan to promote drainage and to allow the droplet filter to dry out when not in use.

If the droplet filter is to be installed against a cooling coil, the droplet filter frames may be able to be screwed directly to the coil frame work without using the SS angles provided. Each installation is different. The installing contractor should use due care and diligence to make sure the air goes through the filter and not by pass it.

The droplet filters will collect water. This water must be drained. It is recommend that a double slope SS IAQ drain pan be used. On roof top installations, care must be taken to prevent freezing of the drain line and trap.

## 7.0 START-UP

### 7.1 Start-Up Procedure

The start-up procedure is also described in the technical manual. Start-up by a factory trained start-up technician is always recommended, however if this is not possible a qualified technician may perform the start-up procedure. First make sure the system is ready to be started. Walk system to make sure nozzle headers are installed level and supported at least every 5'. On in-space systems check that dump valves are installed after zone valves and piped to goose neck approx 6" above headers. Check that orifices are installed on discharge of zone and dump solenoid valves. Check that control panels are mounted properly and are ready. All the water connections must be in place and supply water must be available. All electrical connections must be ready and main power must be available.

It is recommended that the zone headers be flushed by connecting a hose to the end of each header and using the system filtered water to flush the lines. It is not necessary to remove nozzles, just the header end cap.

1. **Make sure main power is turned off.** All circuit breakers should be off and disconnect switches in the open position. Use a meter to test and make sure no power is going to the control box. Make sure the system is ready to be started and that all water and electrical connections are correct. Check each electrical connection at the terminal strip and at the solenoid panels to make sure all the connections are at the correct locations. Make sure all these connections are tight. Make sure all the connections at the circuit breakers and relays are tight.
2. Verify that the wires running from the sensors and high limits to the control panels and from field mounted solenoids to control panels are the proper gauge and go to the proper terminals.
3. Turn the main power disconnect 'ON'. **Be very careful the control box now has high voltage power.** Check the incoming power with a volt meter and make sure it is not fluctuating and that it is not off by more than 10% from the design voltage of the control box.
4. Check the voltages at the secondary side of each control transformer.
5. Plug in pump panel control power plug to local outlet. Make sure all pre-fab cables are properly connected together.
6. On in-space systems, go to each high limit humidistat, open box and rotate the dial CW all the way and then back ¼ turn. Reset the unit by flipping the reset switch up. The red alarm light should go out.
7. Check rotation of pump. With a constant speed system, flip the Auto/Manual switch on pump panel to Manual. With VFD system, start pump using enable and manual switches on pump panel to check rotation of pump. If pump rotation is incorrect, shut down system by going to off on pump panel, open disconnect switch, swap two leads at the motor JB. Recheck rotation.
8. Flip the zone switch on the front of the solenoid panel for zone #1 or Stage #1 on an HVAC system to Open. This will manually open the solenoid valve and the green light on the solenoid panel should be on. Start the pump as above. The feed line and nozzle headers for the selected zone will start filling with water. This may take some time depending on the length of the pipe run to the nozzle header(s). While the pump is pushing the air from the line, the discharge pressure on the pump will be below the low discharge pressure switch setting of 850 psi. This will cause the pump to go off on low pressure and the red alarm light will be lit on the pump panel. Reset the pump by flipping the pump control switch to OFF and then back to Manual. This may need to be repeated multiple times depending on the length of the tubing run. Once the line has filled with water, the pump discharge pressure gauge on the pump should be adjusted to 1000 psi using the regulator. Walk the feed line and nozzle header to check for drips and tighten as needed.
8. Measure the motor amperage using a clamp on ammeter.
10. On systems using the Mee Fog FogStat controller, calibrate the sensors using the procedure in the FogStat manual. Set a reasonable RH value for each zone when complete.

11. To check automatic operation on FogStat systems, place the Auto/Off/On switch to on at the FogStat. Place the pump in Auto. The pump will start and supply high pressure water to the selected zone/stage. Once this has been verified, switch the FogStat to Auto and if pump doesn't start, increase the RH setting for this zone until pump starts. Let the pump run until it shuts off automatically when the set point plus differential is reached.

8. Check the operating pressure when the unit is first started up. Do not exceed 1000 psi. Adjust the pressure control valve as necessary.

## **8.2 Fog System Drain Down Procedure:**

If the fog system is to be shut down for an extended period of time, the following steps should be taken to remove water from the system:

1. Shut off the incoming water supply to the fog system.
2. Run the pump in MANUAL until the low-pressure cut-off switch automatically shuts off the system.
3. Disconnect the high-pressure hose where it is connected to the high-pressure tubing or valve manifold. Lay the hose on the floor and allow the water to drain out of the fog pump.
4. Run the fog pump again in MANUAL until the low-pressure cut-off switch automatically shuts off the system to pump additional water out of the pump.
5. Unscrew the blue plastic filter canister from the caps and dump the water out of the filter sumps.
6. Remove the last fog nozzle from each fogline. Push a piece of 1/2" I.D. flexible vinyl tubing over the end nozzle adapter and run the tubing to a drain. If the system includes zone valves, place these valves in the manual open position. Blow compressed air into the high-pressure hose hook-up port to blow the water out of the foglines. Replace the fog nozzles.

## **8.0 Operation**

### **8.1 Start-Up General Cautions:**

1. Do not exceed the maximum operating pressure of 1000 psi. A pressure gauge is provided on the unit. Look at it occasionally to ensure that the pressure has not gone over 1000 psi. If required, the pressure can be adjusted by turning the hex shaped knob of the pressure control valve while the system is running. Turn clockwise to increase the pressure, counter-clockwise to decrease the pressure.
2. The system has a low-pressure shut-off switch that automatically turns the pump unit off if there is not sufficient water supply or the filters are dirty. If this occurs with your system check for dirty filters or, contact a Mee Industries' engineer and they can assist you with redesigning your water supply system.
3. The system includes a hot water temperature dump valve which dumps some water if the water temperature exceeds 145 degrees F. This can occur if the discharge of the high-pressure pump is closed off, or if too few nozzles are being run on the pump (*refer to the system chart on page 11 for minimum nozzle capacity rate of your unit*). If this occurs the problem needs to be found and corrected to prevent damage to the pump.
4. Be sure the unit has power.
5. Be sure the water supply is turned on.
6. Be sure clean filter cartridges are in place in the filter canister, and the filter drain valve is closed.
7. Be sure the inlet and discharge hoses are connected.

## 9.0 Maintenance

### 9.1 Filter Maintenance:

Excessively dirty filters will restrict water flow into the pump, causing the pump to "cavitate" which is evidenced by excessive noise and vibration from the pump. If the system continues to operate under these conditions, damage to the pump may result.

The filter cartridges should be changed whenever the pressure differential between the inlet and the discharge low pressure gauges exceeds 10 psi. The filter cartridges are located in the filter housing.  
(Refer to page 5 for filter cartridge specifications)

### 9.2 Pump Maintenance:

1. The unit has been shipped with the pumps pre-filled with oil. Spare bottles of oil have been included with the system. This special pump oil is available through Mee Industries.
2. The oil should be changed initially after a 50 hour run-in period.
3. After the initial oil change, the oil should then be changed every 3 months or at 500 hour run-time intervals.

### 9.3 To Change The Pump Oil:

1. Drain the used oil into a pan by removing the plug located below the oil gauge window on the pump. Then replace the plug.
2. Remove the red plastic cap on the oil fill port (this cap has a small vent hole in the center).
3. Fill the crankcase to the dot on the oil gauge window.

## 9.4 Fog Nozzle Maintenance Procedure

### 9.4.1 Changing the filter

Your Fog system has been equipped with filtration and water treatment equipment that should keep your nozzles clean and functioning properly. If, while observing the nozzle in operation, you see that it is performing poorly, remove the nozzle and replace the filter. Follow the two pages attached that show how to remove the old filter and replace it with a new one.

**Always use a Mee Nozzle removal tool in order to protect the nozzle.** Before you replace the new filter, visually inspect the nozzle. If it appears dirty, or scale has formed on it, follow the **Nozzle Cleaning Procedure** outlined below.

Now replace the nozzle and check to see if it is now performing properly. If not, return this nozzle to MEE Industries for refurbishment. You will find it helpful to have a supply of spare nozzles on hand. You can then go through the entire system, note which nozzles are malfunctioning, and replace them with your spares. You can then change the filters of the malfunctioning nozzles at your convenience. Note that it is not necessary to change nozzle filters unless the nozzle is malfunctioning.

***This nozzle filter changing procedure should not need to be repeated more often than 3 to 4 times per year. If you find that you are needing to perform a nozzle filter change more often than 3 to 4 times per year, contact MEE Industries customer service department and let them know what you are experiencing. (1-800-732-5364)***

### 9.5 Nozzle Cleaning Procedure

If while changing the nozzle filter, you noticed scale on the nozzle or its pin, you can dissolve the scale as follows:

- 1) Remove the filter as outlined above and in the attached instructions.
- 2) Soak the nozzles overnight in vinegar (5% Acetic Acid) to remove any scale from the nozzle or pin.
- 3) As a quicker method, you may use a commercially available lime scale remover such as 'Lime-Away'. This should take only 30 to 60 minutes.
- 4) After cleaning as per '2' or '3' above, rinse the nozzles in clean water.
- 5) Replace the nozzle filter and verify that the nozzle is now working properly. If not, return to MEE Industries for refurbishment.

***Note: The cleaning procedure should not need to be performed more often than 1 or 2 times per year. With proper water treatment it is unlikely that scale will form. If you find that you need to perform the scale cleaning procedure more often than 2 times per year, contact MEE Industries customer service and let them know what is happening. It is possible that your water treatment system is not working properly, or, something has changed that needs correction. (1-800-732-5364)***

## **9.6 Nozzle Pin Damage**

Pressing on it or dropping it can easily damage the nozzle pin. Always take care when handling nozzles. If a pin has been bent in any way, or has moved from its original position, it will not function properly. If this has occurred, return the nozzle to MEE Industries for refurbishment.

## 9.7 Removal of MEE Nozzle Filters

**Important:**

When removing the nozzle filters, the Mee Nozzle Removal Tool (nozzle holder & filter puller) must be used. When removing the nozzle filters, failing to use the appropriate tool may result in severe damage to the fog nozzle.

1. Screw the fog nozzle (*finger tight only*) into the Nozzle Holder.

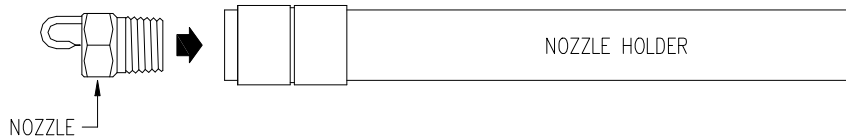

2. Slide the Filter Puller into the Nozzle Holder.

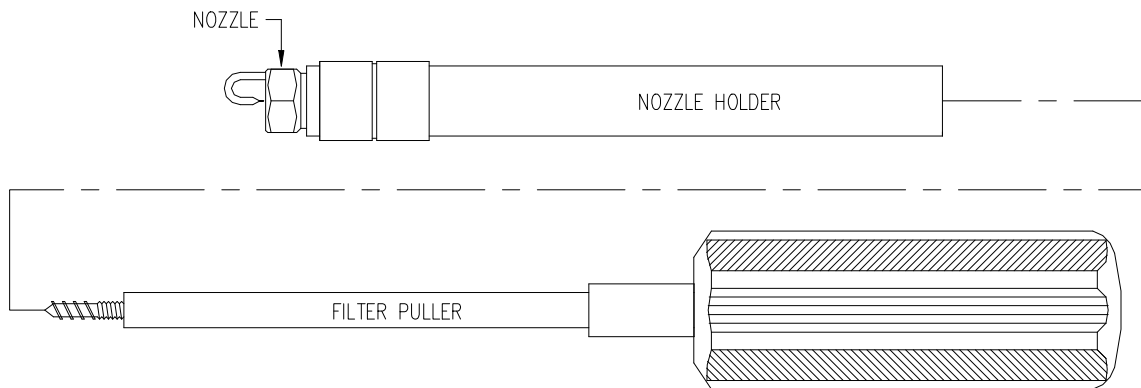

3. Holding the fog nozzle with your fingertips, screw the Filter Puller clockwise into the nozzle filter until the Nozzle Holder bottoms onto the handle of the Filter Puller.

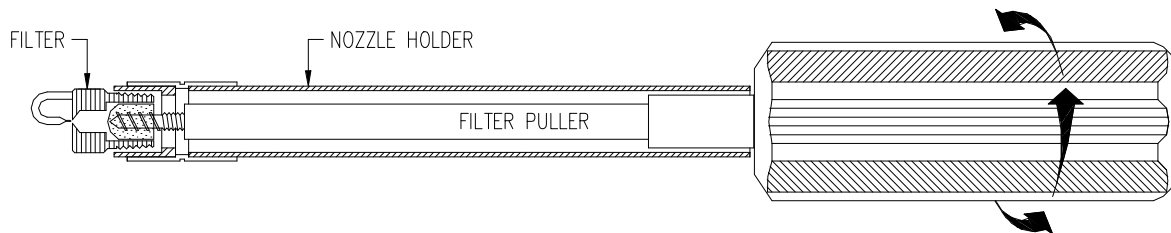

4. Pull the filter out of the nozzle by pulling the Nozzle Holder and Filter Puller apart.

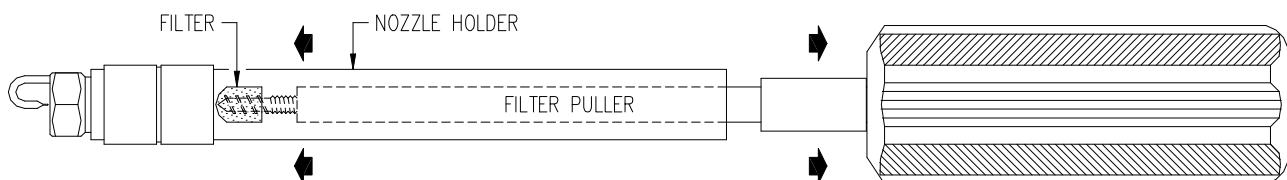

## 9.8 Installation of MEE Nozzle Filters

1. Inspect the fog nozzle to ensure that it is clean. If not, refer back to NOZZLE CLEANING PROCEDURE.
2. Before installing into the fog nozzle, wet the filter.
3. Hold nozzle with the open-end facing upward.

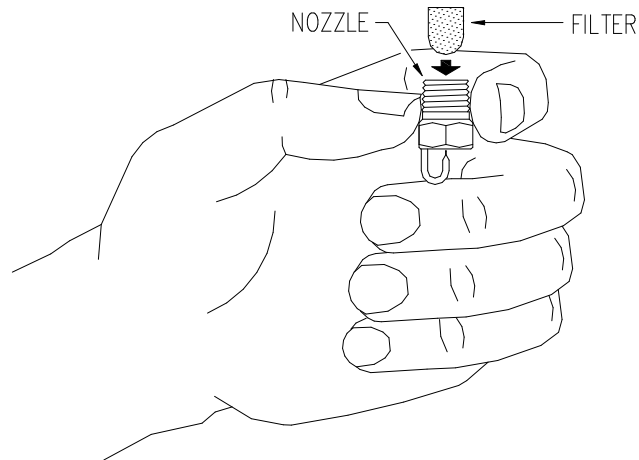

1. Place the rounded side of the filter into the nozzle opening.
2. Turn the nozzle and filter upside down and place against a flat surface.
3. Place your thumbs on either side of the impaction pin and gently press the filter into the nozzle. Make certain that the filter is not at an angle while pressing the filter into the nozzle. Be careful not to knock the impaction pin out of alignment while pressing the filter into the nozzle.

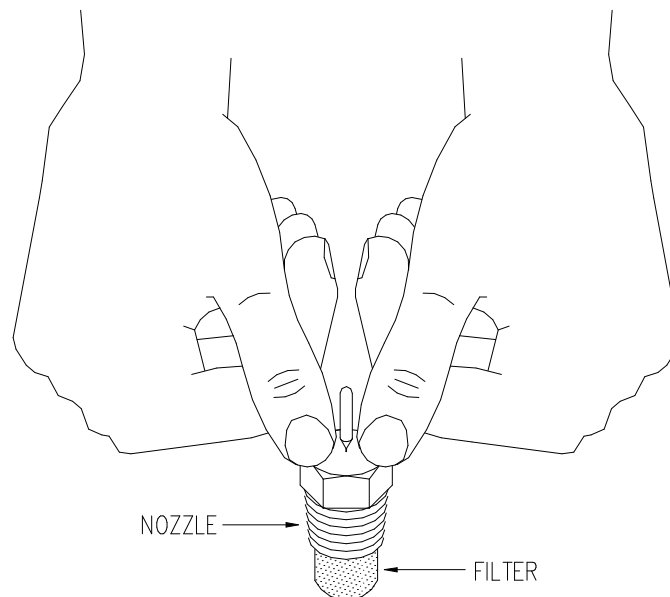

### 9.9 Improper Fog Nozzle Handling

# IMPORTANT! CAUTION!

DO NOT TRY TO ALIGN THE NOZZLE IMPACTION PIN YOURSELF!

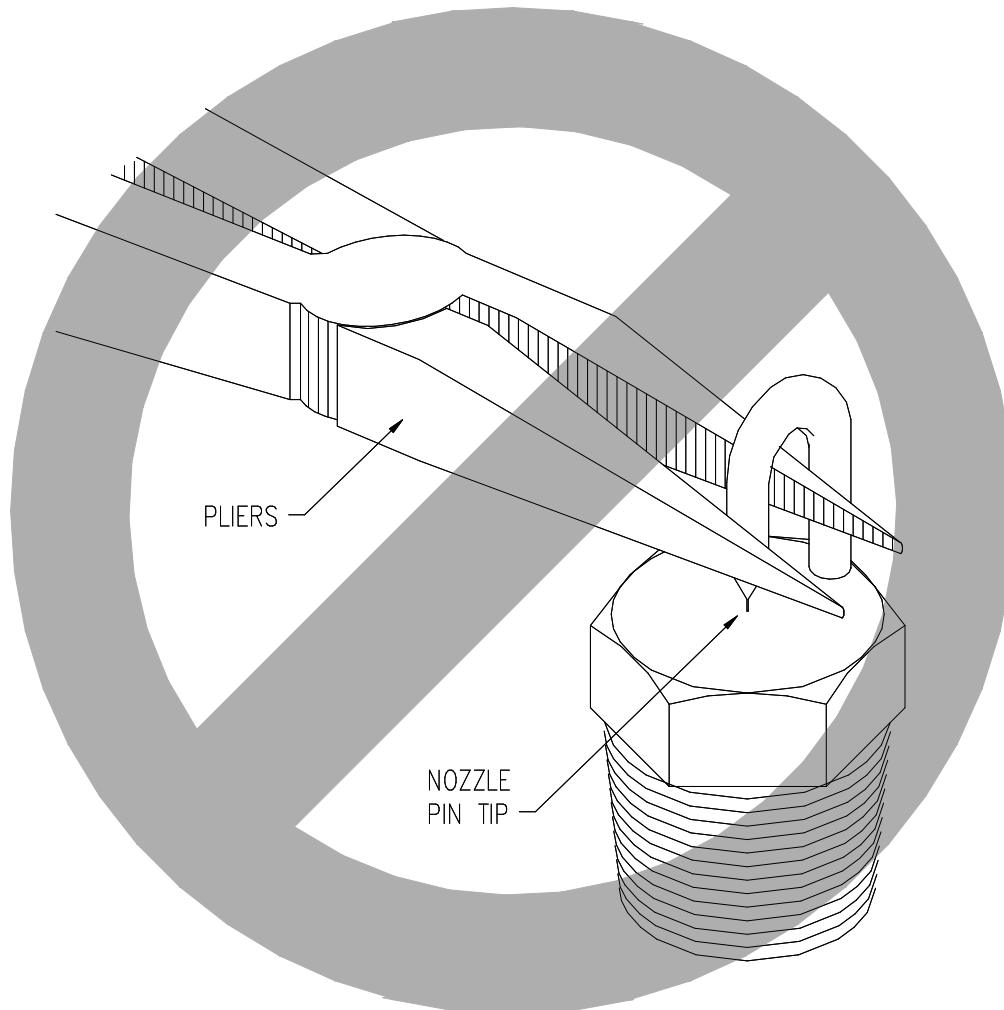

1. The nozzle orifice can be marred beyond repair if the impaction pin is collapsed into it.
2. Do not use wrenches, pliers, socket wrenches, or vice grips to tighten or handle the nozzles.
3. They can damage the impaction pin itself and/or collapse the impaction pin into the orifice.
4. Nozzles that do not work correctly should be returned to Mee Industries for reconditioning. Use Mee Red Caps to protect fog nozzles when modules are to be moved with the nozzles still installed. Always use Mee Nozzle Packing Foam whenever nozzles are to be stored or transported after removing from the fog modules. This helps to protect the nozzle bodies.

## 10.0 Troubleshooting Guide

\* **NOTE:** *Electrical component troubleshooting should be performed by a qualified electrician or by a Mee Factory Technician. Refer to the system's wiring diagrams for the electrical layout.*

**Problem: 1. Unit starts, runs about 5 seconds, then shuts off.**

**Check:**

- 1a) **Filters** to see if they are dirty. If unsure try re-placing filter cartridges with new ones and see if problem goes away.
- 1b) **Incoming water supply** valve should be open, and line pressure should be 15-70 psi. There should be no restrictions in the line.
- 1c) **Setting** of low-pressure cut-off switch. The setting should be at 5-10 psi.
- 1d) **Red fault light.** If this light comes on instantly when unit is switched on, the pressure switch may be bad.

**Problem: 2.. Unit will not start in the manual or auto mode. \***

**Check:**

- 2a) **Incoming line voltage** at the unit to be sure it is turned on, is the correct voltage, and is not going through an extension cord.
- 2b) **Thermal overload protector** (located inside the electrical box). For single-phase units: push the green reset button to reset tripped units. For three phase units: check the *tripped window* to see is the overload has been engaged. If necessary, push reset button to reset. (Located to the right side of *tripped window*.)
- 2c) **24 volt circuit** inside the electrical box. There should be approximately 24 volts ac between the 24v neutral and terminal 2. If terminal 2 is dead, check 1 (before 2 amp fuse). If 1 is dead, check transformer.  
- If terminal 2 has 24 volts, set the panel switch to *MANUAL* and check the voltage on terminal 4. If 4 is dead, check for a bad low-pressure cut-off switch.
- 2d) **Mercury switch.** For 115v, single phase units: when the panel switch is on *MANUAL*, there should be high voltage at both ends of each pole of the switch.
- 2e) **Motor starter.** For all other units: when the panel switch is on *MANUAL* there should be high voltage at both ends of each pole of the switch.

**Problem: 3. Unit runs but produces little or no fog.**

**Check:**

- 3a) **Pressure gauge.** If the pressure gauge reads approx. 1000 psi, check to be sure fog is being emitted from the fog nozzles. Open any closed manual or electrically actuated valves if necessary. Never operate the fog pump against a closed discharge or damage to unit may result.  
- If valves are open, check for plugged fog lines or nozzles.  
- If gauge is reading less than 1000 psi, adjust the pressure regulator.  
- If pressure still will not come up, look for leaks in the high-pressure lines. (If a leak is found and repaired, be sure the pressure regulator is turned back down before starting up unit or damage to unit may result.)

**Problem: 4. Unit shuts off by itself and will not re-start in manual or auto mode.**

**Check:**

- 4a) Perform steps 2b, 2c, 2a, and 2d in that particular order as required.

**Problem: 5. Unit continually trips circuit breaker or thermal overload device unit. \***

**Check:**

- 5a) **Location of unit** to be sure it is not being exposed to excessive heat from the sun, heaters or furnaces, other equipment, etc. Also ensure that any enclosure around the unit is providing adequate ventilation to the unit.
- 5b) **Incoming line voltage** to be sure it is the correct voltage labeled on the serial tag of your unit, and power is not being supplied through an extension cord.
- 5c) **Pump** to be sure it has sufficient oil. The oil level should be to the middle of the view window on the back side of the pump. Also, listen for any sign of damage.
- 5d) **Filters** to make sure they are clean. Replace, if needed with same type of filter cartridge.
- 5e) **Water supply pressure** to ensure there is adequate pressure on inlet.
- 5f) **Amp setting** of adjustable type overload to make sure it matches motor.

- 5g) **Operating pressure** to make sure it is not higher than rated pressure.(1000 psi on standard units.)

**Problem: 6. Unit will not operate in auto mode. (Units with 24-hour clock.) \***

**Check:**

- 6a) **Clock** to be sure it is set correctly.
- 6b) **Supply voltage** to clock to be sure it is on, and is the correct voltage for your clock. The clock voltage is indicated on the wiring diagram. (Consult an electrician, or a Mee Factory Technician.)
- 6c) **24 volt supply** inside box. (See step 2c.)
- 6d) **Switch in the clock.** Check for continuity between terminal 3 and 4 on the back of the clock:
- First, pull out several programming tabs at the 12 o'clock position on the clock dial.
  - Then, rotate the dial clockwise until the pulled-out tabs are at the white arrow at the 2 o'clock position.
  - Finally, remove the wires from terminals 3 and 4 on the back of the clock and check for continuity between those two terminals.
- If there is no continuity, the switch is bad and the clock should be replaced.

**Problem: 7. Unit will not operate in auto mode. (Units with thermostat)**

**Check:**

- 7a) **Thermostat.** Remove the thermostat cover and ensure that the test switch is in the *AUTO* position, the power indicator on and the 24-hour clock, if so equipped, is on. (See step 6d.)
- In *COOL* mode the control output will turn on when the sensor temperature rises to the set point plus the differential. In *HEAT* mode the control output will turn on when the temperature falls to the set point minus the differential. The control output always turns off at the set point.

**Problem: 8. Unit will not operate in auto mode. (Units with repeat cycle timer) \***

**Check:**

- 8a) **Repeat Cycle Timer (RCT).** Ensure that the 24-hour clock is on, if so equipped. (See step 6d.)
- 8b) **Supply voltage** to the RCT to be sure it is on, and is the correct voltage for your RCT. The correct voltage is indicated on the wiring diagram, and it can be checked at terminals A (hot) and B on the back of the RCT. (Consult an electrician, or a Mee Factory Technician.)
- 8c) **24 volt supply** inside box. (See step 2c.)
- 8d) **Switches in the RCT.** Check for continuity between terminals 4 & 7 and 6 & 9 on the back of the RCT:
- First, remove the wires from these terminals.
  - Then, set the *OFF TIME* knob to the minimum setting and *ON TIME* knob to the maximum setting.
  - Finally, place the main control switch (located on the front of the main panel) to the *OFF* position and then back to the *ON* position.
- The *ON TIME* LED should light up. If not, go to step 7b. If the *ON TIME* LED is lit, you now can check for continuity between terminals 4 & 7 and 6 & 9 on back of the RCT.

**Problem: 9. 24v fuse keeps blowing. \***

**Check:**

- 9a) **Fuse** to be sure correct sizes are being used. The corresponding size of each is indicated on wiring diagram. Be sure to use the same type of fuses supplied with the system.
- 9b) **Transformer.** There should be approximately 24 volts ac between terminal 2(hot) and neutral. If the out put from the transformer is low, this can cause excessive current draw through the fuse.
- 9c) **24 volt devices** (high and low pressure solenoid valves, 24-hour clock, thermostat, and mercury switch):
  - First, disconnect the white wires from the 24v(neutral) terminal.
  - Then, put the switch in the *MANUAL* position.
  - Finally, reconnect the devices one at a time.Repeat this process until the device that is causing the fuse to blow has been isolated. (Consult an electrician, or a Mee Factory Technician.)

**Problem: 10. Unit begins making very loud noises accompanied by an erratic dropping of pressure or an erratic pulsation observable on the pressure gauge (cavitation). \***

**Check:**

- 10a) **Incoming water supply** to be sure line pressure is sufficient, and pump is not being starved for water. Check the filter element to make sure it is clean. (A dirty filter is the most usual cause of this problem.)
- 10b) For **any restrictions** in the incoming water supply, such as a valve or piping that is too small.
- 10c) **Quantity of output** from unit. If there are an insufficient number of nozzles in operation, the flow rate through the pump becomes too slow. When this occurs, the water in the pump can heat up too much forming air bubbles in the water.
- 10d) **Pump** for damage or for debris in the pump. For disassembly instructions on your pump model, contact a technical service representative at Mee Industries. The model is labeled on top of pump.

**Problem: 11. Unit will not run, motor makes a humming noise.**

**Check:**

- 11a) **Incoming line voltage**, see step 2a.
- 11b) **Electrical connections** inside the junction box on side of the motor for loose or dirty connections, and ensure motor is wired correctly for your voltage by checking information plate on the motor. The motor is wired differently depending on the incoming voltage.
- 11c) **Quantity of output** from unit. If there are an insufficient number of nozzles in operation, the flow rate through the pump becomes too slow. When this occurs, the water in the pump can heat up too much forming air bubbles in the water.
- 11d) Mercury switch/motor starter, see step 2d. Also, check for burnt or loose terminals and/or connectors.



## **APPENDIX**

- Appendix A Mee Fog Technical Information Letter  
TIL-101 dated April 7, 2004, Version  
1.1, "Maintaining Fog System  
Cleanliness"
- Appendix B MeeFog Design Guide DG-H103,  
Version 1.1 dated October 5, 2005,  
"Stage Control of Mee Fog Systems"
- Appendix C Mee Fog TIL-H100, Dated April 7,  
2004, Version 1.1, "Calculating  
Evaporation Efficiency"



# MeeFog Humidification Systems

## Maintaining Fog System Cleanliness

TIL-101  
June 1, 2006  
Version 1.1  
Appendix A

### Importance of Maintaining Cleanliness

If the humidification section of the air handling unit (AHU) becomes dirty, it is possible for mold and bacteria to grow and multiply. Dirt usually contains mold spores and bacteria, as well as being a source of food for them. Maintaining a dirt free humidification section greatly reduces the likelihood of mold and bacteria growth.

The humidification section should have easy access to allow for inspection and cleaning. After installation of a fog system, the humidification section should be inspected regularly to determine a reasonable cleaning schedule. The humidification section may have to be cleaned more frequently during periods of heavy dust or dirt loading, such as during construction, remodeling or moving.

### Importance of Proper Water Treatment

The water supplied to the fog system should always be low mineral content water, treated either with a demineralization system or a Reverse Osmosis system. Mineral content in the water is a source of food for some bacteria. Furthermore, when the fog evaporates any minerals present in the water will remain in the air, as airborne dust, and can present a housekeeping problem.

Fog system supply water should also have Anti-microbial treatment, such as Ozonation, Chlorination or UV treatment. It is particularly important to ensure that any water storage tanks are equipped with a dust/dirt cover and have an appropriate anti-microbial treatment system.

Some anti-microbial treatments do not have residual kill ability. UV systems kill only those bacterial that pass through the UV device and Ozone has a very short lifespan in most water systems. If a water storage tank is treated with UV, the water should be continuously pumped through the UV device. If Ozone is used it should be intermittently applied to ensure that an adequate Ozone level is maintained.

### Drainage Systems

If water is allowed to stand, stagnant for more than a day or so, the likelihood of microbial growth increases

dramatically. It's important to ensure that drain-pans have operating drains and that no pooling of water occurs. It's also important to insure that drains have proper P-traps, so that foul air cannot be suctioned from the drain lines. Drain pans should be periodically washed with a suitable anti-microbial cleaning solution.

### Fog Droplet Filters

Droplet Filters should be inspected and cleaned if they are found to be dirty. Red colored droplet filter media, as supplied by Mee Industries, has anti-microbial Silver ions as an integral part of its fibers. Microbes will not grow on the filter material so long as it is kept clean. If your fog system has the white colored droplet filter media, or other non-Mee supplied media, you may want to consider replacing it with the red colored media. Droplet filters can be spray-cleaned in place, or they can be removed and soaked in an anti-microbial solution, such as water with a small amount of Chlorine bleach mixed in.

Fog droplet filter should not be allowed to stand in stagnant water. It is best if the bottom of the filter is not allowed to be in contact with the drain pan.

Before an AHU is turned off, the fog system should be shutdown and some time should be allowed for drying the droplet filters and duct surfaces.

Fog droplet filters should be installed so there are no gaps or holes where fog can pass through, this could result in duct wetting downstream of the humidification section.

### Fog Nozzle Lines

If the fog system supply water is free of dissolved minerals and particulate dirt, there should be little possibility for microbial growth in the fog lines themselves. However, if a system is to be shut down for an extended period of time, it is best to drain the lines. Alternatively, the fog system can be automatically turned on for a few minutes each day to flush stagnant water from the lines.



## MeeFog Humidification Systems

### Maintaining Fog System Cleanliness

TIL-101  
June 1, 2006  
Version 1.1  
Appendix A

#### **Maintenance Checklist**

Inspect the humidification section and clean if dirt is found on duct walls, drain pans, droplet filters, etc.

Establish an inspection and cleaning schedule.

If water is pooling and standing stagnant in the drain pans, correct the situation.

Inspect the drainage system to ensure that air is not being suctioned from drain lines.

Consider replacing droplet filter media with the red colored anti-microbial filters, which are available from Mee Industries.

Review the control scheme to ensure that the AHU does not shutdown when the humidification system is still wet.

Consider modifying the control system so that the fog is operated for a few minutes each day, to flush stagnant water from the feedlines and fog lines.

Inspect the water treatment system to ensure that any storage tanks are clean and that a suitable anti-microbial system is in place and operational.

### Stage Control of MeeFog Systems

#### The MeeFog Valve Controller

##### The MeeFog Valve Controller

The MeeFog Controller consists of an Allen Bradley, MicroLogic 1500 Programmable Logic Controller (PLC) and a PanelView 300 Operator Interface Terminal, Figure 4.0. The PLC is a Base Unit with a fixed number of analog and digital inputs and outputs (I/O) and a microprocessor unit. Additional I/O can be added as needed.



**Figure 4.0 The Allen Bradley MicroLogic PLC & the PanelView 300, OIT**

As a stand-alone controller the PLC can be used with either an analog-output humidity sensor (4-20 mA or 0-10 volt DC) or with a simple humidity switch (a humidistat switch that closes when humidity is not required and opens when humidity is required). One MeeFog PLC can control as many as ten (10) solenoid valves, which can be installed on multiple AHUs.

##### MeeFog Valve Controller – Theory of Operation

The MeeFog Controller acts to open and close the staging valves in the proper sequence, so as to maintain the required humidity level in the treated space. When humidity is required the Controller waits for a user-set number of seconds then opens and/or closes solenoid valves so that the fog output goes to the output stage. When less humidity is required, the Controller backs off on stages, waiting each time for the user-set time delay.

When a high-humidity signal is received from the high-limit humidistat, the Controller backs off on fog stages until the high-humidity signal goes away. When the airflow switch indicates no airflow in an AHU, all of the valves are closed. The Controller also turns ON the fog pump unit whenever a solenoid valve is opened and turns OFF the pump whenever all solenoid valves for that pump are closed. Operating the Fog Pump with all valves closed could damage the pump due to excessive heating as water flows through the pressure bypass loop.

### **MeeFog Valve Controller Inputs and Outputs**

The standard MeeFog Controller comes with the following input and outputs (I/O).

<b>Qty</b>	<b>Type</b>	<b>Description</b>	<b>Use</b>
4	Analog Inputs	0-10 VDC or 4-20 mA	Input from humidity sensors or BAC
12	Digital Output	Relays	Control of valves & pump
12	Digital Inputs	Relays	Input from switches; humidistat, airflow switch.

Additional I/O modules can be added.

### **Safety Interlocks**

There are two safety interlocks that are important for controlling MeeFog systems:

**High Humidity Switch (HHS):** This device should be located in the duct downstream of the Fog Droplet Filters. It can be either a humidistat (a simple switch closure) or a humidity sensor (analog output of relative humidity). The purpose of the switch is to avoid injecting too much humidity into the air stream. The MeeFog Controller will back off on fog stages if this humidistat indicates too much humidity.

**Airflow Sensor (AS):** This device disables the fog system, for the AHU in question, if there is no airflow in the AHU.

These interlocks can be wired directly to the MeeFog Controller or they can be wired to the BAC, which then sends the signal to the MeeFog Controller only if the safety interlocks are satisfied.

### **Humidity Signal Given to the MeeFog Controller**

There are several options for the humidity signal that is given to the MeeFog Controller.

- A simple humidity switch (humidistat) can be connected to one of the PLC's digital inputs. With this method the MeeFog PLC adds stages as long as the humidity switch is closed—delaying by the user-set time delay as each stage is added or removed.
- An analog signal can be sent directly from a relative humidity sensor.
- An analog signal can be sent from a building automation computer (BAC).

### **Specifying I/O for the MeeFog Controller**

Figure 5 shows a typical chart for specifying I/O for the MeeFog Controller.

It is important to sum the different types of I/O so that the proper PLC I/O modules can be selected. It is also important to show the scale for analog signals. Here they are shown as 4 to 20 milliamp (mA), but signals can also be 0 to 10 volt DC.

Typical Project - XYZ Inc.			Date:	Oct. 05	By:			Joe Sepcifier
			Digital Input	Digital Output	Analog Input	Analog Output	Analog Scale	
							4 mA	20 mA
Fog Pump				1				
AHU 1	Stages:	15	Make-up Air Unit with 90 nozzles (six per stage)					
Control Humidity Sensor					1		0% RH	100% RH
Signal to BAC (stages "on")						1	Stage 1	Stage 15
High-Humidity Switch			1					
Airflow Switch			1					
Valves (4)				4				
AHU 2	Stages:	7	10% OA, 28 nozzles (4 nozzles per stage)					
Control Humidity Sensor					1		0% RH	100% RH
Signal to BAC (stages "on")						1	Stage 1	Stage 15
High-Humidity Switch			1					
Airflow Switch			1					
Valves (3)				3				
AHU 3	Stages:	3	10% OA, 12 nozzles (4 nozzles per stage)					
Control Humidity Sensor					1		0% RH	100% RH
Signal to BAC (stages "on")						1	Stage 1	Stage 3
High-Humidity Switch			1					
Airflow Switch			1					
Valves (2)				2				
Totals ...			6	10	3	3		

**Figure 5.0 shows a typical chart for specifying I/O for the MeeFog Controller.**

### **Instrumentation Diagrams for Different Configurations**

Figure 6.0 shows a typical control diagram for a stand-alone MeeFog Controller with a simple humidistat (humidity switch) as the controlling sensor. There is no BAC in this control scheme. Control set points are entered at the humidistats located in the air stream and in the treated space, not at the MeeFog Valve Controller itself.

This control scheme doesn't require analog I/O for the PLC because all the inputs and outputs are digital. This is one of the least expensive options for using the MeeFog Controller because it doesn't require expensive humidity sensors.

Don't forget that at least one of the digital outputs from the PLC must be used to tell the MeeFog Pump to start when a valve is open, and to stop when all valves are closed.

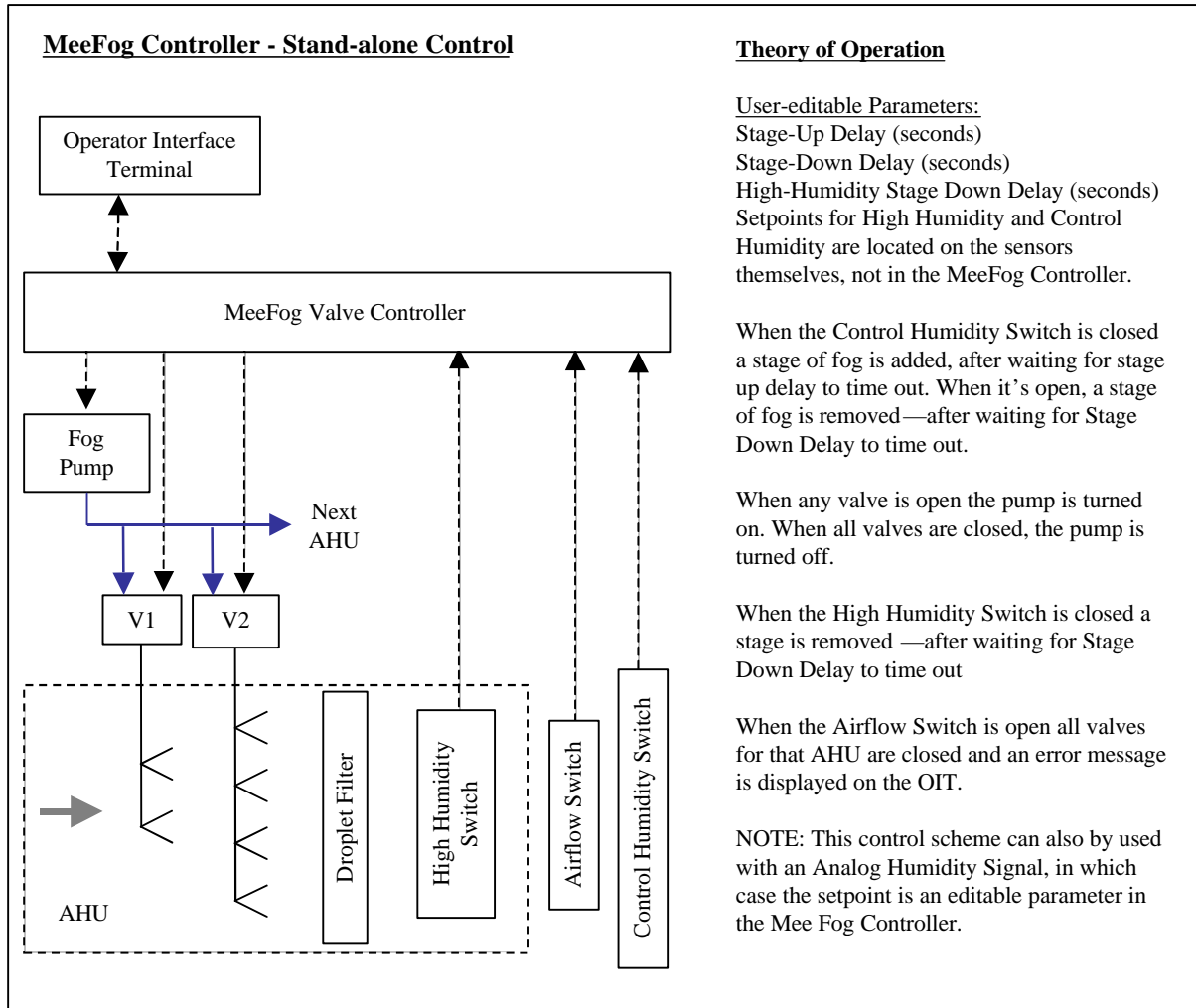

**Figure 6.0 Diagram of Stand-Alone MeeFog Controller**

Figure 5.0 also shows an optional analog output from the PLC called, "Signal to BAC." This output tells the BAC how many fog stages are currently in operation.

This control scheme doesn't require analog I/O for the PLC because all the inputs and outputs are digital. This is one of the least expensive options for using the MeeFog Controller because it doesn't require expensive humidity sensors. It also allows the end-user to set the humidity setpoint at the sensor, which can be located in the treated space.

The MeeFog Controller can control valves on multiple AHUs. It's only necessary to select enough I/O for the PLC.

Figure 7.0 shows a typical control diagram for a MeeFog Controller connected with a Building Automation

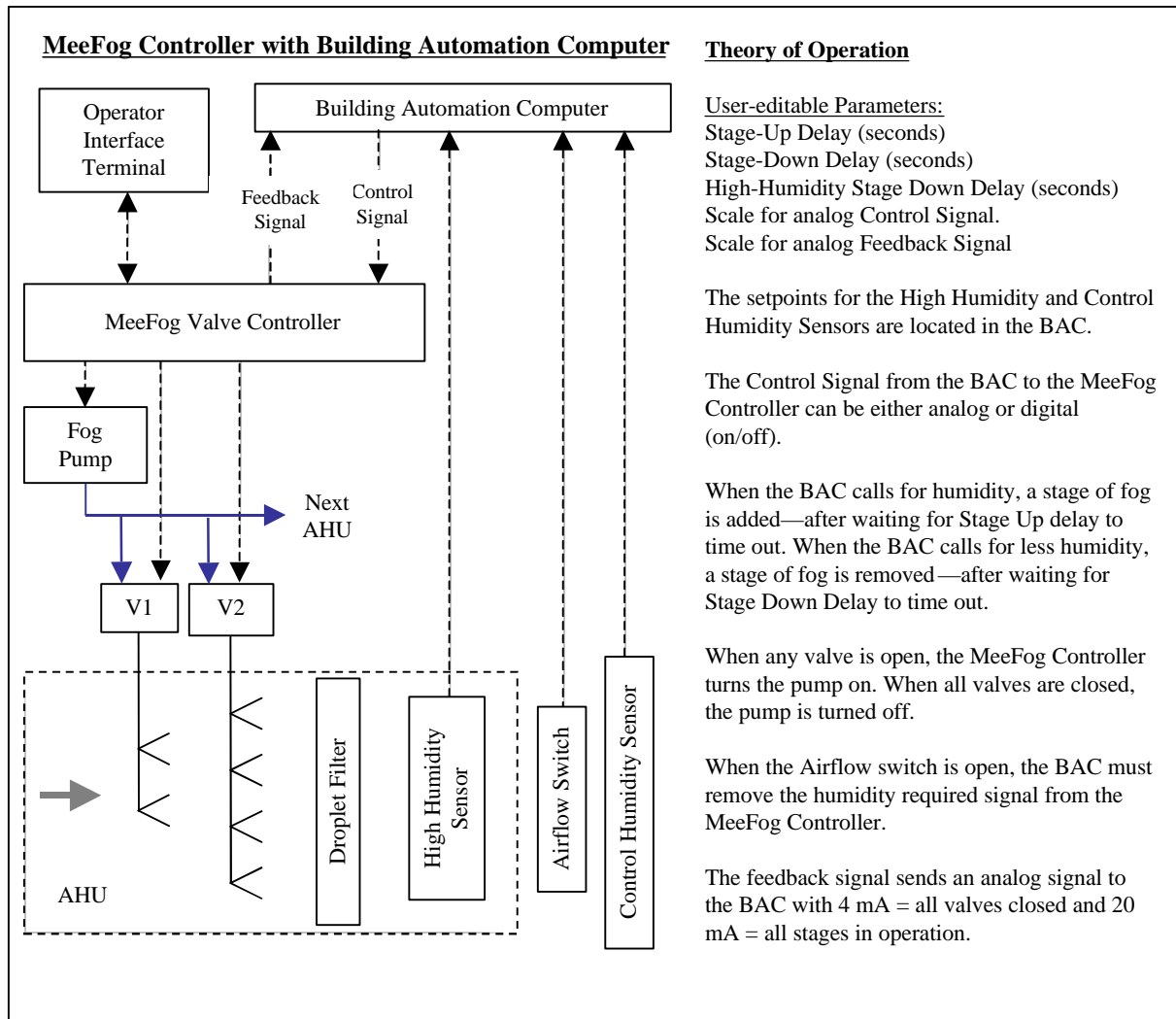

**Figure 7.0 MeeFog Controller with a Building Automation Computer (BAC).**

### MeeFog System Controlled by a Building Automation Computer

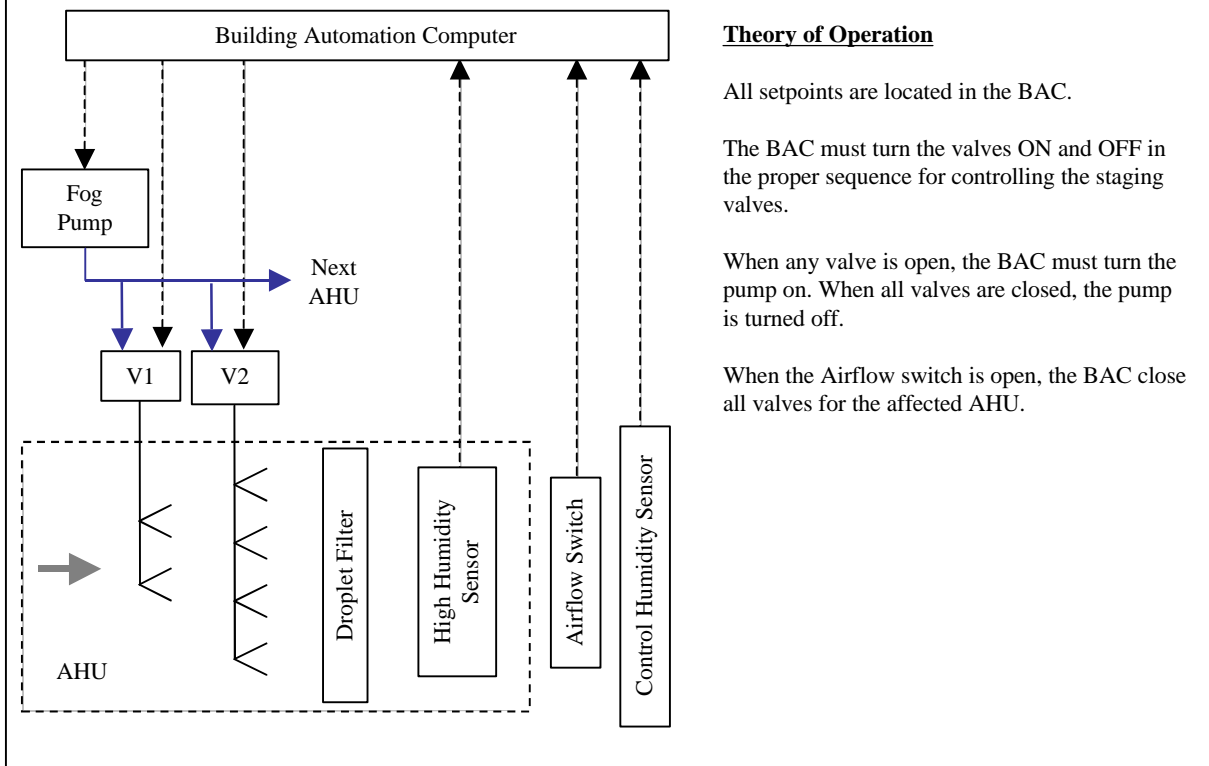

The MeeFog Controller can control valves on multiple AHUs. It's only necessary to select enough I/O for the PLC. But keep in mind that the wires connecting the valves and the MeeFog Controller should not be more than 200 feet long.

#### **Variable Pressure Control:**

With this control scheme the fog system pump speed is controlled with a variable frequency drive (VFD). As the demand for humidity increases, the fog pump speed is increased. Speeding up the fog pump unit causes (1) higher flow through the fog nozzles, which results in more humidity output, and (2) higher operating pressure, which results in smaller droplets and more efficient evaporation.

**MeeFog Humidification Systems**  
**Calculating Evaporation Efficiency**

**Typical MeeFog Installation**

A typical MeeFog installation consists of a manifold of high-pressure nozzles located in the air-handling unit. At an operating pressure of 1000 psi a standard MeeFog Nozzle (IP-16) has an output of 16 pounds per hour (0.032 gpm). Ninety percent of the water output is in droplets that are equal too or smaller than 24 microns in diameter—about one fourth the diameter of a single strand of hair.

Fog Droplet Filters are used to ensure that no water droplets are carried over into the air ducts. Cooling coils are also effective droplet filters and are often used for that purpose. Your MeeFog application specialist can assist you with determining which option is best for your project.

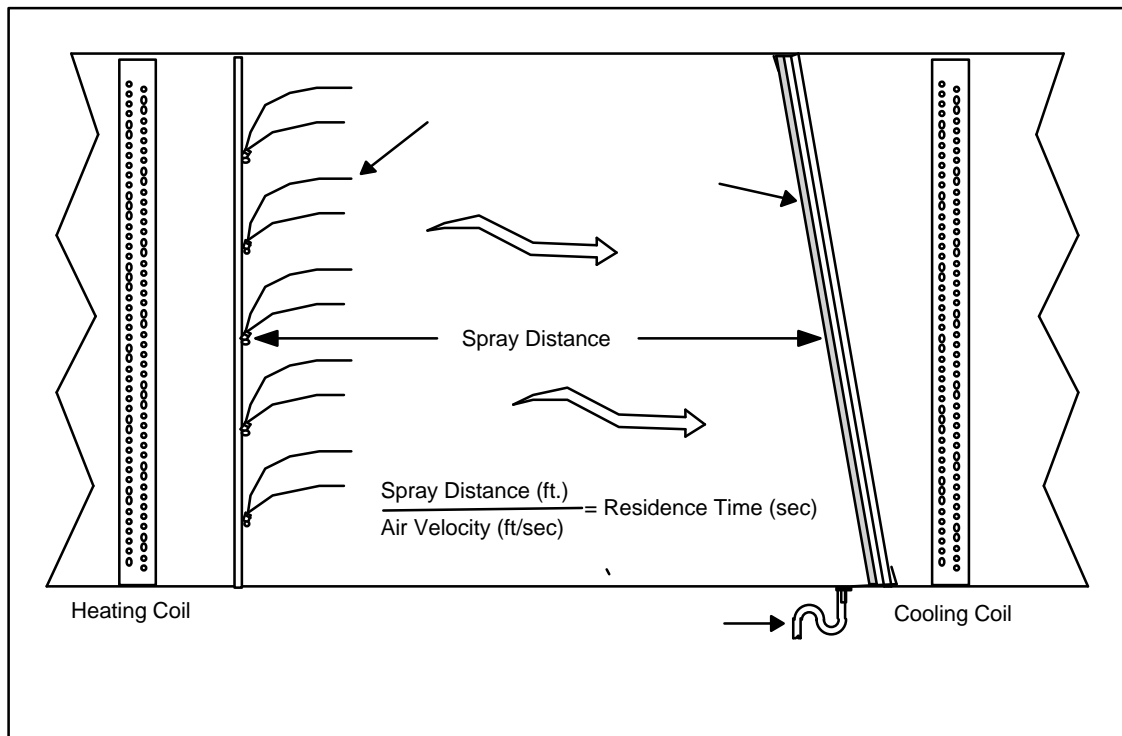

**Calculating Evaporation Efficiency**

Evaporation Efficiency is defined as the percentage of the total water flow that evaporates before being captured on the Droplet Filter or Cooling Coil. For instance, 80% Evaporation Efficiency means that 80% of the sprayed water evaporated and entered the air stream as humidity while 20% was captured on the Droplet Filter and drained away.

The amount of water that will evaporate before being collected on the Droplet Filters depends on the residence time of the droplets in the air stream, the size of the droplets, the entering air humidity and temperature and the water temperature. The spray distance and airflow velocity determine the average residence time. To find the Evaporation Efficiency, simply compute the residence time (see the equation in the previous figure) and look up the Evaporation Efficiency on the following chart.

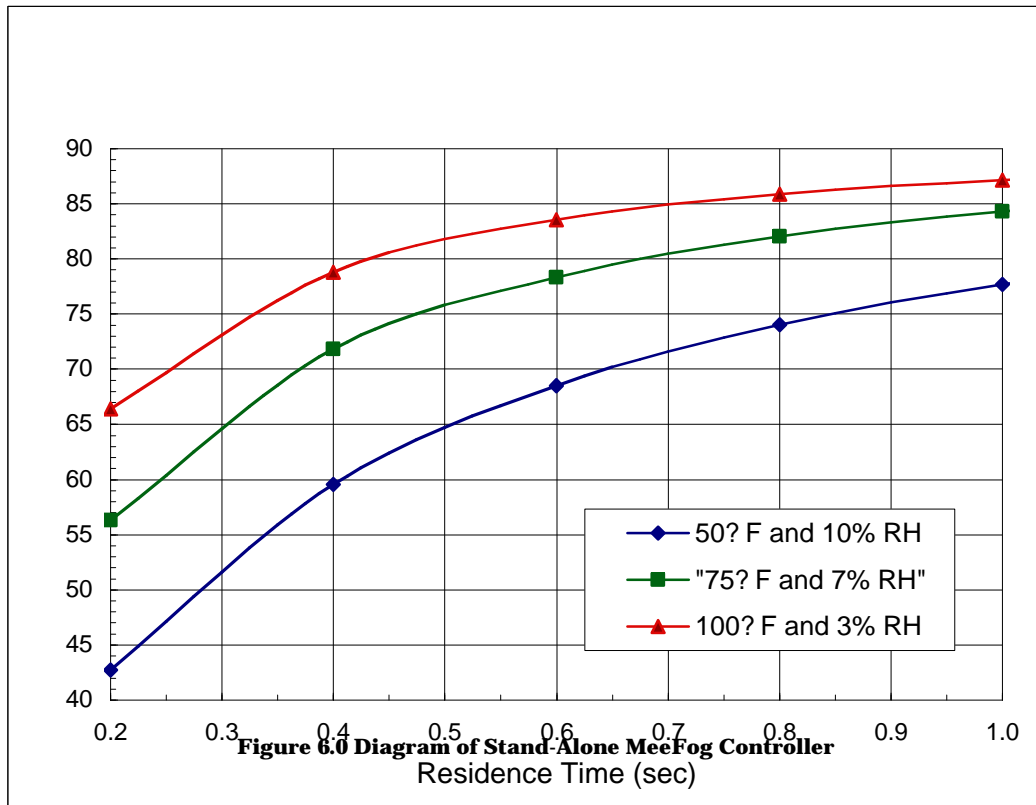

M E E I N D U S T R I E S I N C .

PROPRIETARY INFORMATION

This information is submitted in confidence for evaluation only and its contents are proprietary to Mee Industries Inc. The recipient of this document agrees not to reveal the contents, or any part thereof, to any person or company beyond those in its own organization or another organization reporting to it for the sole purpose of evaluating it or to perform any resulting contract. In no event is it to be revealed to a third party without the prior written consent of Mee Industries Inc. No copy of this document, or any part thereof, may be made without such consent.

**[www.meefog.com](http://www.meefog.com)**  
H U M I D I F I C A T I O N D I V I S I O N